

CHALLENGER

YOUR PARTNER IN A MORE SECURE FUTURE

AA61(12V2.2AH)SLA Battery

Outer dimensions (mm)

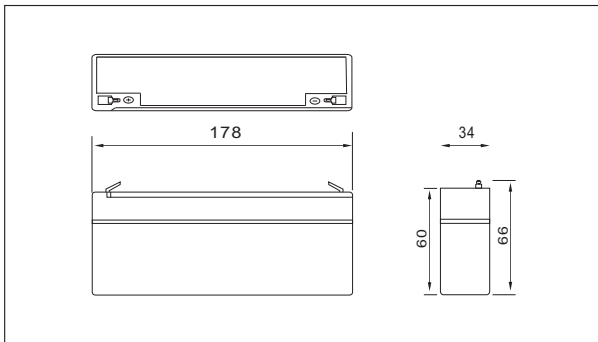

Terminal Type (mm)

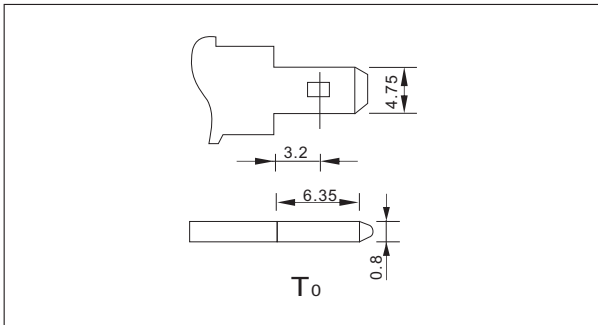

Specifications

Nominal Voltage	12V	
Rated capacity (20 hour rate)	2.2Ah	
Dimensions	Length	178±1.5mm(7.01inch)
	Width	34±1mm(1.34inch)
	Height	60±1mm(2.36inch)
	Total Height	66±1mm(2.60inch)
Weight Approx	0.90kg(1.98lbs)±3%	



Characteristics

Capacity (25°C)	20HR(10.5V)	2.20Ah
	10HR(10.5V)	1.80Ah
	1HR(9.60V)	1.14Ah
Terminal type		T0
Internal resistance (Fully charged, 25°C)		Approx. 55mΩ
Capacity affected by temperature (20AH)	40°C	102%
	25°C	100%
	0°C	85%
	-15°C	65%
Self-discharge (25°C)	3month	Remaining Capacity:91%
	6month	Remaining Capacity:82%
	12month	Remaining Capacity:65%
Nominal operating temperature		25°C ±3°C(77°F ±5°F)
Operating temperature range	Discharge	-15°C~50°C(5°F~122°F)
	Charge	-10°C~50°C(14°F~122°F)
	Storage	-20°C~50°C(-4°F~122°F)
Float charging voltage(25°C)		13.60 to 13.80V Temperature compensation: -18mV/°C
Cyclic charging voltage(25°C)		14.50 to 15.00V Temperature compensation: -30mV/°C
Maximum charging current		0.6A
Maximum discharge current		33A(5 sec.)
Desigend floating life(20°C)		5 years

Constant Current(Amp) and Constant Power(Watt) Discharge Table at 25°C(77°F)

Time		5min	10min	15min	30min	1h	2h	3h	4h	5h	8h	10h	20h
9.60V	A	8.28	5.43	4.03	2.65	1.38	0.81	0.59	0.48	0.40	0.27	0.22	0.12
	W	85.9	58.3	43.2	28.4	14.9	8.84	6.59	5.35	4.59	3.05	2.51	1.38
10.20V	A	7.59	5.19	3.70	2.51	1.30	0.77	0.58	0.46	0.40	0.26	0.21	0.12
	W	81.5	58.1	41.4	28.2	14.7	8.90	6.66	0.35	4.61	3.06	2.51	1.36
10.50V	A	6.91	4.85	3.45	2.43	1.25	0.76	0.57	0.44	0.39	0.26	0.21	0.12
	W	75.9	55.2	39.4	28.0	14.5	8.78	6.59	5.11	4.62	3.04	2.50	1.36
10.80V	A	6.64	4.64	3.22	2.37	1.21	0.74	0.56	0.43	0.37	0.25	0.21	0.11
	W	74.5	53.5	37.1	27.4	14.1	8.64	6.55	5.07	4.42	2.99	2.45	1.34
11.10V	A	6.14	4.37	2.99	2.30	1.17	0.72	0.53	0.42	0.36	0.25	0.20	0.11
	W	69.6	50.6	34.8	26.9	13.7	8.50	6.26	5.02	4.27	2.94	2.43	1.32

Note: The above characteristics data can be obtained within three charge or discharge cycles.

Construction

Component	Positive plate	Negative plate	Container	Cover	Separator	Electrolyte	Safety valve	Terminal
Raw material	lead dioxide	Lead	ABS	ABS	AGM	Sulfuric acid	Rubber	Copper / lead

● Discharge characteristics(25°C)

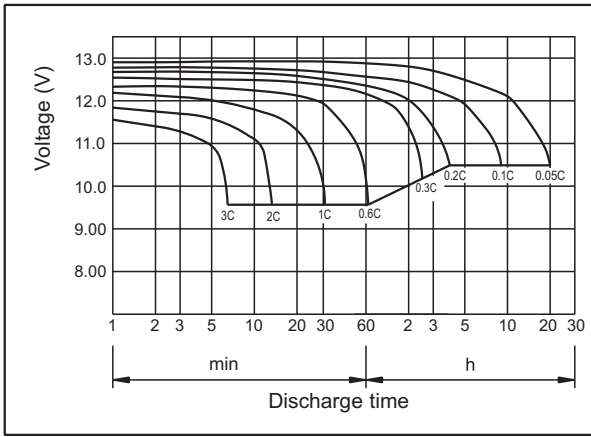

● Charging characteristics

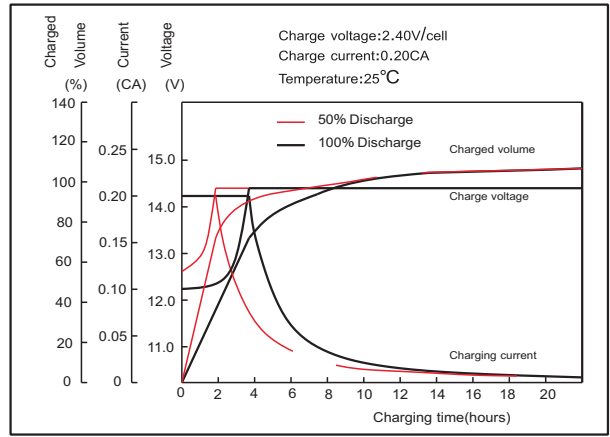

● Temperature effects on Capacity

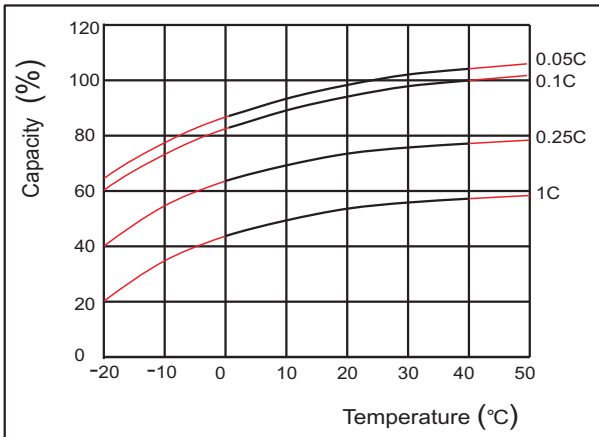

● Self-discharge characteristic

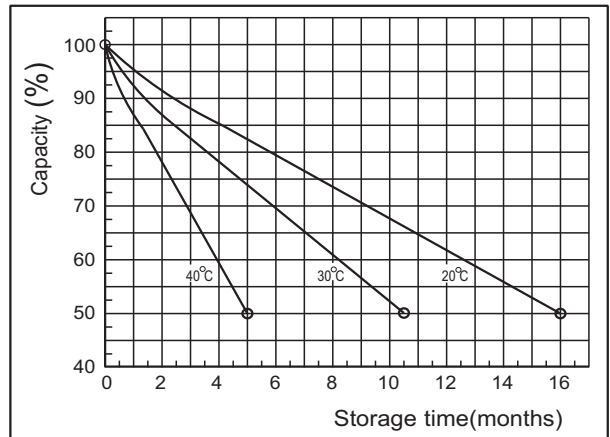

● Temperature effects on float life

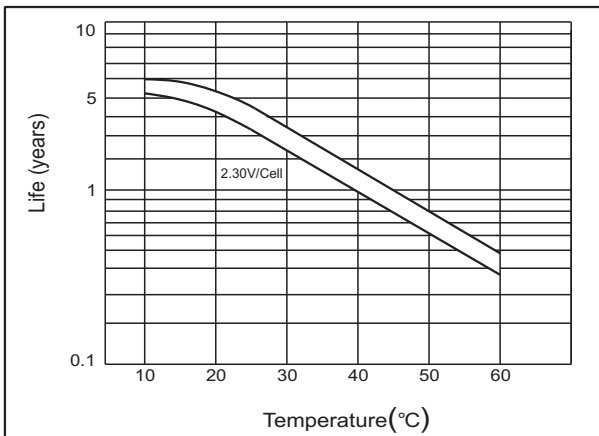

● Cycle service life in relation to depth of discharge

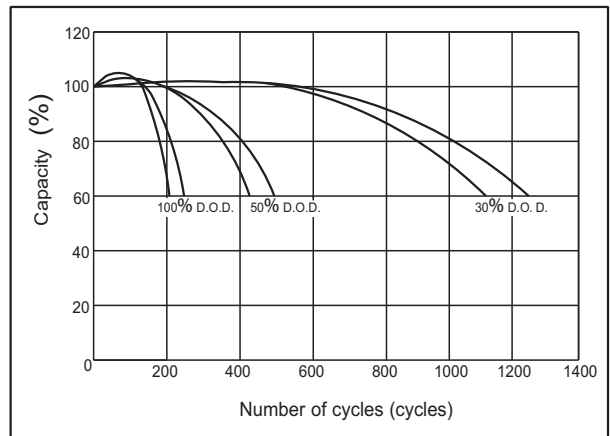

● The relationship for OCV and Capacity (25°C)

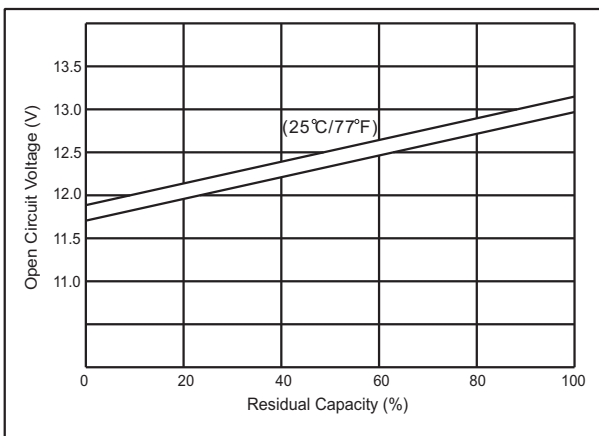

● The relationship for Charging voltage and Temperature

