

Intruder alarm system

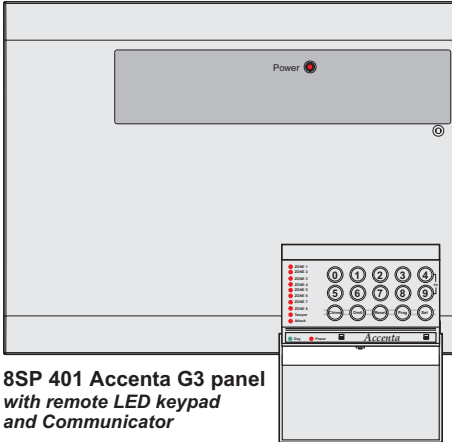

Engineering Information



**8SP 401 Accenta G3 panel
with remote LED keypad
and Communicator**

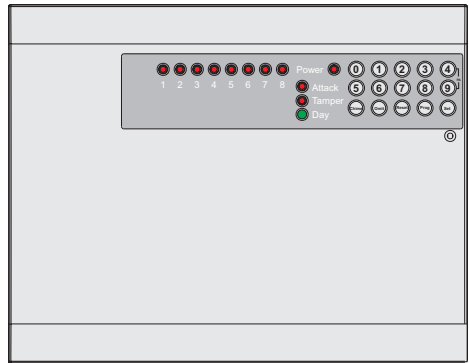

**8EP 395 Optima G3 panel
with built-in keypad
and communicator**

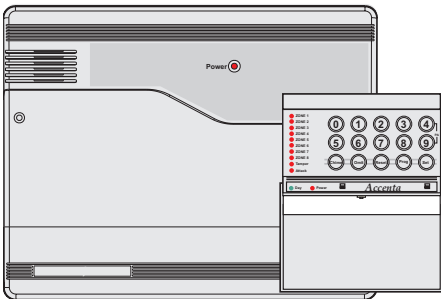

**8SP 400 Accenta mini G3 panel
with remote LED keypad
and communicator**

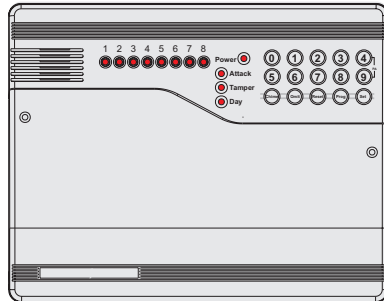

**8EP 396 Optima compact G3 panel
with built-in keypad**

The above intruder systems are designed to comply with the installation requirements of BS 4737 1986/87.

This manual provides information on Installation design, panel fixing, wiring, power up and programming of the intruder panels.

Features

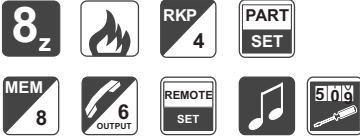

- 8 zones, all programmable for Security, Fire, 24H Fire, PTS or keyswitch applications
- PA input
- Tamper input
- Outputs for External siren (Bell) and Strobe
- 4 Access level Codes, User 1, User 2, Engineer and Duress, all programmable
- 3 fully selectable part set programs
- Chime on any zone
- 8 event memory
- Programmable timers including bell cut off
- Walk Test facilities
- Quick set feature
- Remote keypad with on board PA and illuminated keys standard for Accenta panels and Optional for Optima panels
- Option for connection of Lighting controllers
- Options to connect up to four remote keypads / Lighting controllers
- NVM for protection of engineer programme
- 6 digital outputs for a wire-in digital communicator, Red Care STU or dialler **(Not applicable for Optima compact G3 panel)**
- Service warning indicator, programmable between 100 and 800 set and unset events
- Battery capacity of up to :
2.1Ah in Accenta/Optima G3 mini enclosure
7Ah in Accenta/Optima G3 enclosure
- Optima G3 and Optima G3 compact are supplied with built in keypad**

Contents

Features - - - - -	2
Installation Design - - - - -	3
Fixing the control panel - - - - -	3
Wiring the system - - - - -	5
Tamper network - - - - -	5
Connecting Remote Keypads /	
Lighting controllers - - - - -	5
Fitting the Remote Keypad - - - - -	5
Security zones - - - - -	6
Push to set zone - - - - -	7
Remote keyswitch zone - - - - -	7
Fire zone - - - - -	8
PA circuit - - - - -	8
Extension speaker - - - - -	9
External siren Output (Bell box) - - - - -	10
13V Supply output - - - - -	11
Set - - - - -	11
Remote signalling Input and Outputs - - - - -	12
Filtering of Intruder alarms - - - - -	13
Factory set condition - - - - -	14
First Power up - - - - -	15
Mains Connection - - - - -	15
Testing the system - - - - -	16
Engineer program mode - - - - -	16
To exit operation - - - - -	16
System indications - - - - -	16
To enter Engineer program mode- - - - -	16
To Exit Engineer program mode - - - - -	16
To reset panel to Factory set conditions - - - - -	16
Access Codes - - - - -	17
Zone Type - - - - -	18
Zone Attributes- - - - -	19
Programs - - - - -	20
Zone Function per Program - - - - -	20
Exit Modes program - - - - -	20
Programs 1,2 and 3 - - - - -	21
Alarm and Walk tests - - - - -	22
Communicator tests - - - - -	23
'Flag A' Options - - - - -	23
'Flag B' options - - - - -	24
Viewing the event log - - - - -	24
External siren (Bell box) and Service Timers - - - - -	25
Re-arm and Anticode reset code - - - - -	26
Lighting controller - - - - -	27
Faults - - - - -	28
Specification- - - - -	29
Servicing organisation Details - - - - -	31
Parts - - - - -	31
Quick Reference - - - - -	32

Installation Design

The purchase of this alarm system represents a major step forward in the protection of the property and its occupants. It is important to plan the installation before proceeding following the procedures and advice contained in this manual.

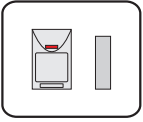

Plan the position of each part of the alarm system and the cable runs. **Detectors** should be sited with particular regard to the degree of coverage required

and the function of each of the zones.

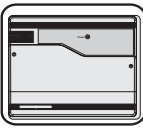

All of the system wiring is connected directly to the **panel**. The Accenta panel may be concealed inside a cupboard or loft space, but it must be installed within the protected

premises and in a position which is convenient for a mains supply. The Optima panel may be installed near an entry/exit point.



The **Remote keypads (RKP)**s should be mounted in positions which allows ease of operation for the system users, typically within the entry/exit route close

to the final door and the master bedroom.

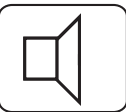

Additional internal **sound speakers** are recommended, these will provide high volume alarm tones and low volume entry/exit tones. Speakers should

be positioned to provide good sound distribution throughout the building and so that the exit tone is audible outside the main entry / exit door. This will enable the system operator to check that the system is setting correctly.



Finally note that the **total current** output of this control system (in alarm condition) is 1A when supported by a fully charged battery. Calculate the total

current consumption of every part of the system including the panel, remote keypads, external siren with strobe light (also called bell box) and

detectors to ensure that this rating is not exceeded.



Depending on which area you live, you may be required, by law to notify the **Local Authority** and Police of the new security alarm installation. The

local authority requirements may differ from area to area, therefore, it is advisable to contact local environmental officer to obtain full details of your area requirements.

Fixing the control panel

Caution: When positioning the control panel ensure that it is located in a dry place away from damp areas.

The Accenta mini G3 enclosure is illustrated here, however the procedures for the other panels are similar.

- a. Remove the front cover(s) from the base assembly.

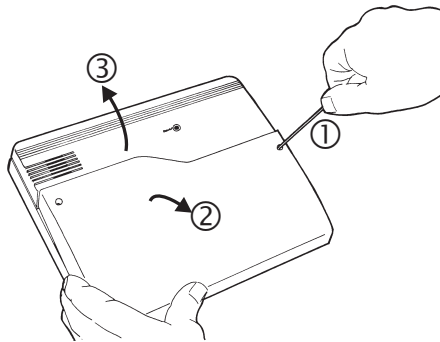

Disconnect the transformer wires from the board, these are marked **AC**. Carefully remove the board by gently pushing down the holding clips on the bottom edge of the board and withdraw it from the base.

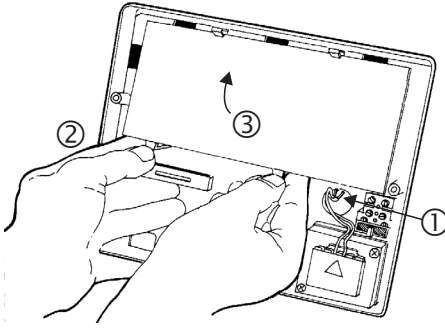

Note: When replacing the board align it on the round support pillars to the bottom and allow it to click down past the clips at the top of the case. Refit the transformer wires into the terminal.

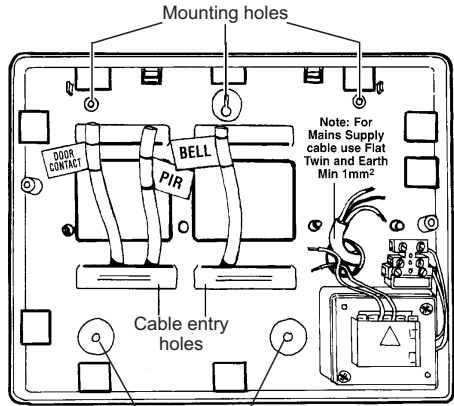

Danger
High Voltage
~ 230V 50Hz 0.2A
FUSE T125mA 250V
(ANTI-SURGE)

- b. Fit the panel to the wall with suitable fixings. Ensure the wall surface is flat to prevent base distortion. There are cable entry holes provided in the rear of the base and around the outside edges through the thinned out plastic sections which may be cut away as required.
- c. The hole provided adjacent to the mains transformer is a dedicated mains cable entry point.

Board

There are four fuses mounted on the circuit board, all are 20mm quick blow.

- F1 1.6A - to protect the +ve line of 12V battery
- F2 1A - to protect the RKP 13V supply
- F3 1A - to protect the Speaker 13V supply
- F5 1A - to protect the Siren (Bell) & Strobe supply

As supplied, wire links are fitted across the PA and Tamper terminals to represent a closed circuit.

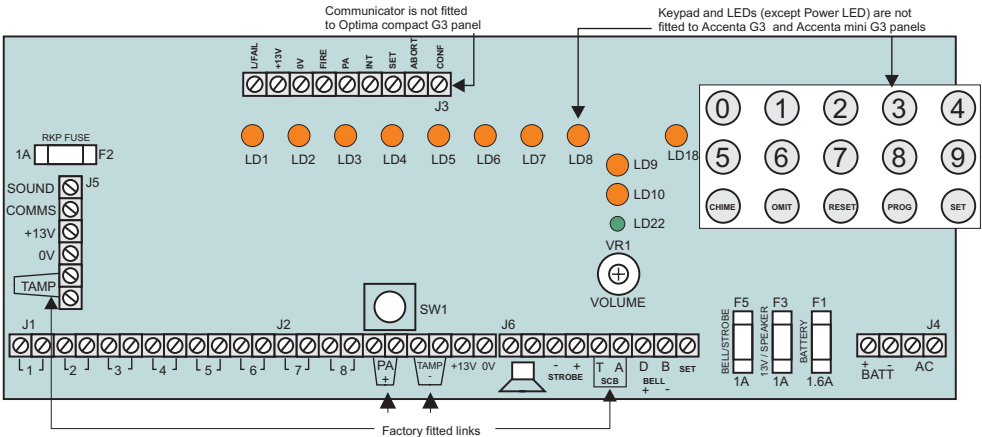

Wiring the system

Caution: Always **power-down** the panel when wiring external circuits, to prevent damage to the panel electronics.

Systematically wire and test each circuit:

- Zone, Tamper circuit and PA circuits
- Finish by wiring any additional extension speaker sounders, external siren (bell) / strobe and the 13V supply.

Tamper network

The Tamper circuit is used to protect all cables and detectors in the system from unauthorised access including the panel and RKP covers.

The zone and PA tampers should be series wired and connected to the TAMP terminals. Terminals T & A are for the external siren tamper. The TAMP terminals at the bottom left of the board are for the RKP tampers.

Tamper alarms that occur in the Day mode operate internal sounders only. Tamper alarms in Set cause a full alarm condition. Tamper is indicated on the control panel and RKPs by the **Tamper** indicator.

Connecting Remote Keypads / Lighting controllers

Note: Where an Accenta G3 or Accenta mini G3 panel is being installed ensure there is at least one remote keypad wired to the panel before first power up.

A combination of up to four remote keypads and lighting controller can be connected to the panel.

Fitting the Remote Keypad

- d. Separate the RKP baseplate from the main assembly by slackening the retaining screw.
- e. Cut away the required thin wall sections around the edges of the baseplate for cable entry.
- f. The baseplate mounting holes are 60mm centres which allow it to be fixed to a single gang electrical metal box. As an alternative the baseplate may be fitted directly to the wall using the screws and wall plugs supplied, if these are not appropriate for the wall then use suitable alternative fixings.

Caution: The PCB board must not be removed from the front moulding and doing so may invalidate the warranty.

- g. Bring the cables into the baseplate and wire to the terminal block on the baseplate, see diagram on the next page.
- h. Refit the RKP main assembly to the baseplate by hooking it onto the top holding clips. Check that the wiring does not foul the tamper switch/spring or the PCB support pillars. Resecure the screw in the bottom of the case.

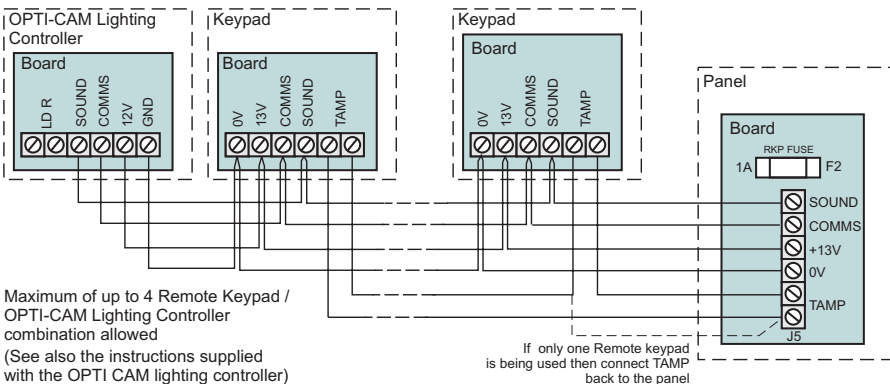

Wiring the system

Security zones

Security zones

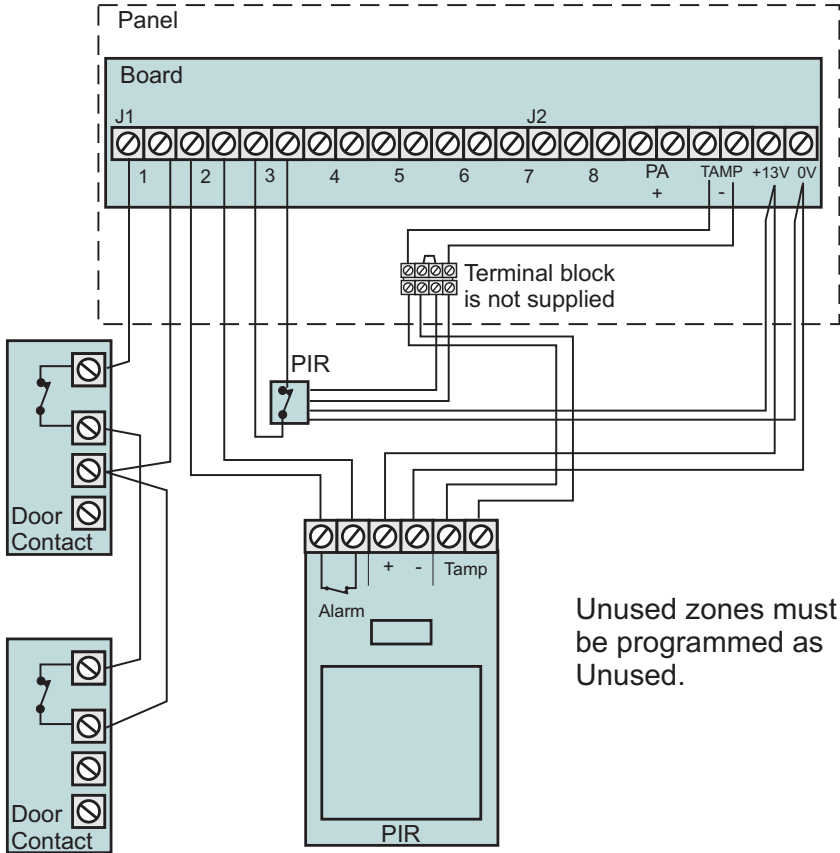

Note: The G3 range of panels are **not supplied with wire links** for unused zones. All unused zones must be programmed out by setting them to *disabled* using the **Zone Type** function see page 18.

It is recommended that no more than 10 magnetic contacts are connected to the same zone.

Push to set zone

Any zone can be wired and configured as a Push to Set input. This can be a standard door bell push located outside the premises. After starting the exit timer the building is vacated. As the switch is then momentarily closed, a chime tone is produced and the system Sets. Sometimes referred to as 'Terminate Set' this facility is mandatory for communicating systems installed to NACOSS guidelines

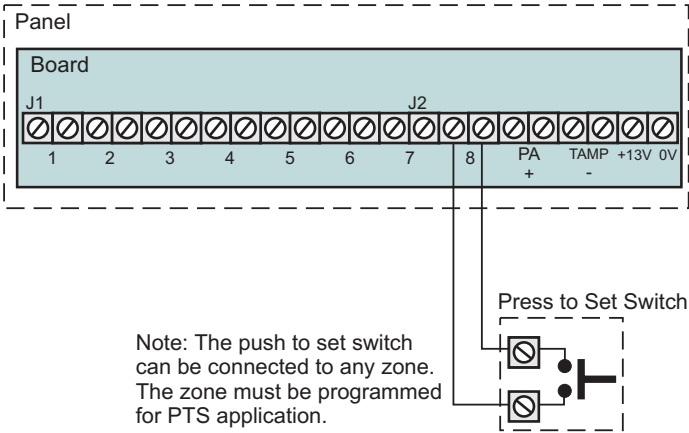

Remote keyswitch zone

Any zone can be wired and programmed as a keyswitch input and used with a remote keyswitch or lock switch. For security reasons it is recommended that a tamper proof switch is used and that the switch wiring is not accessible from outside the premises.

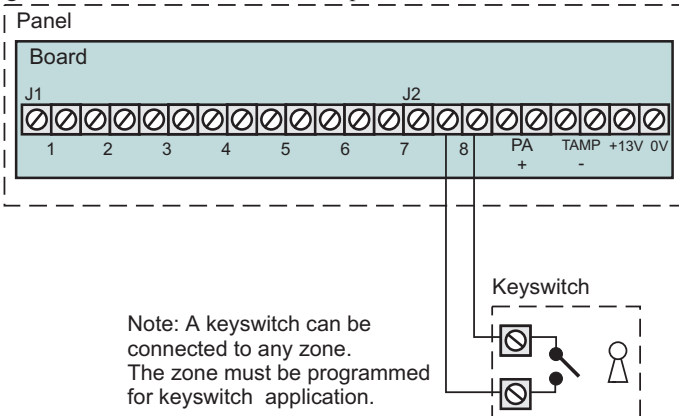

The keyswitch may be used to Set (open contacts) or Unset (closed contacts) independently of RKP's. However in this situation the keyswitch may have to 'catch up' with the system. For example if the system is Set via an RKP and Unset with the keyswitch, it would have to be momentarily turned to its Set position then returned to its Unset position.

The keyswitch will always Set program 1. It will also Unset the system or switch off an alarm activation. To Reset after an alarm and return to Day mode, the Reset key on the RKP will have to be pressed.

Push to set zone

Fire zone

Any zone may be programmed as a fire zone. This will automatically exclude the availability of the zone from programs and normal security applications.

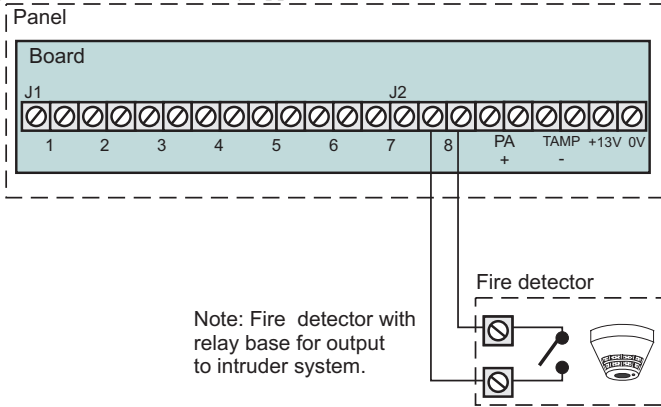

There are two types of fire zone, **Standard** and **24 hour** type. The **Standard fire** zone detects fires only when the system is Set, whereas the **24 hour fire** zone detects fires all the time and will operate whether the system is Set or Unset. A fire will cause a distinctive internal sounder tone. The external sounders will pulse on and off at 2 second intervals and all RKP indicators will flash the affected zone.

PA circuit

Any quantity of normally closed type personal attack button may be wired in series and then connected to the PA circuit.

Operational in Day and Set, the PA circuit will cause a full alarm condition when activated. PA is indicated on the control panel or RKP as Attack.

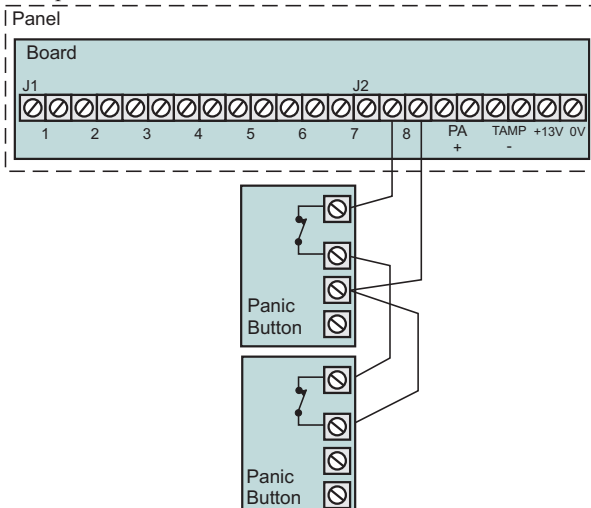

PA buttons may be fitted near the front door, or in a bedroom.

Extension speaker

Extension speaker may be connected to the loudspeaker terminals to produce high volume alarm tones and low volume entry / exit fault tones.

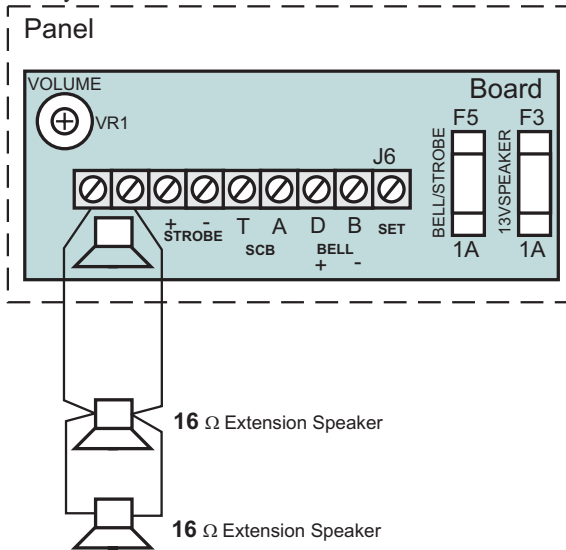

Up to two 16 ohm extension speakers may be wired across the speaker terminals. Mounted in convenient positions within the installation the extension speakers will reproduce all of the alarm tones generated by the control panel.

A control marked **VOLUME** in the centre of the board may be used to adjust the low volume entry/exit tones to suit environmental conditions.

External siren Output (Bell box)

The external siren (bell box) is usually installed in a high position from where the siren could be seen and heard.

Terminal T A D B are for connection to the external siren. These terminals provide a power/hold-off supply, sounder trigger and tamper circuit to protect the external siren housing.

External siren Output (Bell box)

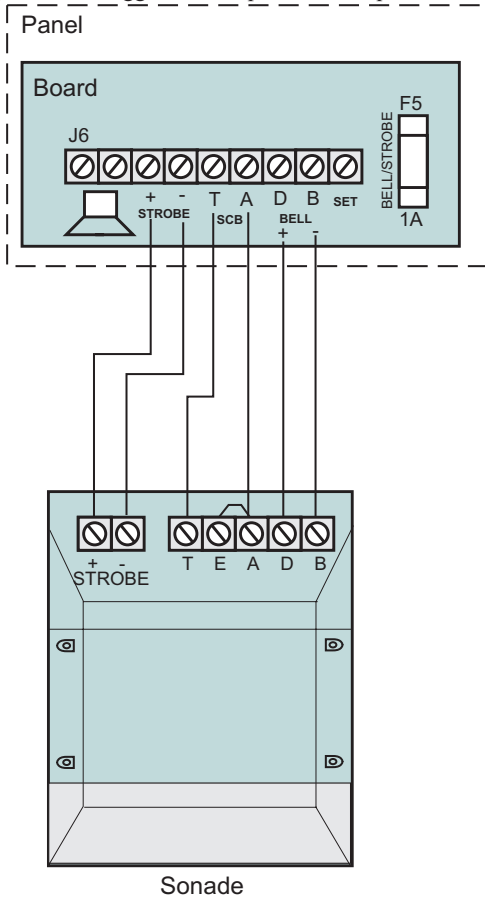

The terminals are summarised as follows:

- T - -Ve tamper return
- A - -Ve supply (0V)
- D - +Ve supply (12V)
- B - -Ve Sounder trigger

For ease of installation, ADE external sirens and modules use the same markings.

Where a discrete external siren is used, it should be connected to terminals D & B. Terminals T & A are then used for tamper protection for the housing.

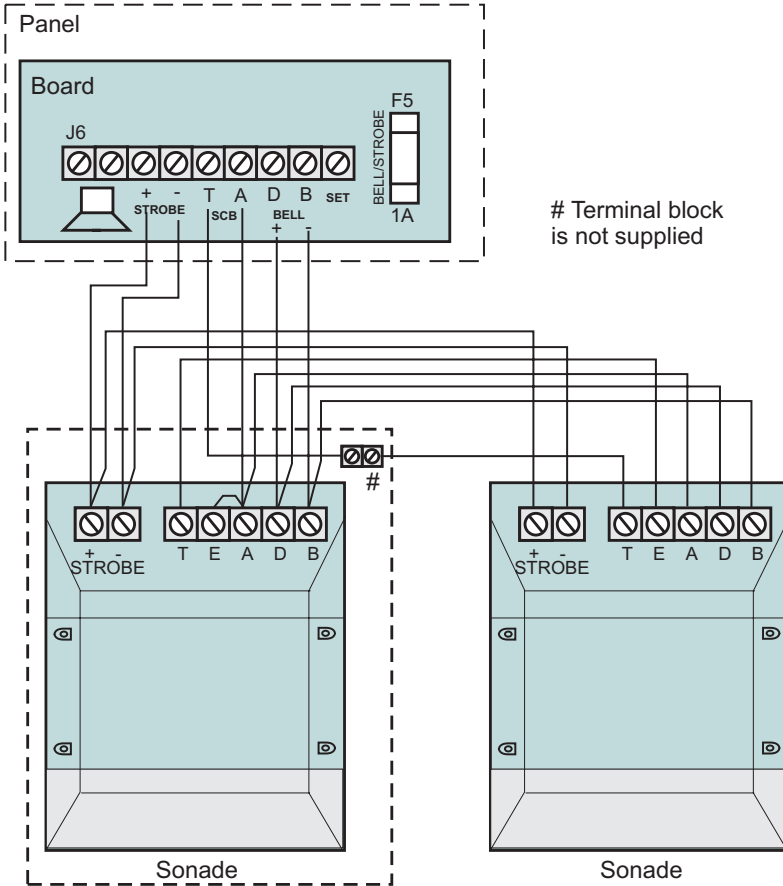

13V Supply output

Where self contained / powered sounders are used, carefully follow the manufacturers instructions, match each of the terminals to those above.

13V Supply output

The 13V output is to power detectors which require a voltage supply (PIR detectors etc). The supply is present at all times and may be used to supply a total load of 350mA.

Set

The output, marked SET is used with latching detectors. The output becomes positive on correct Set of the system and is removed at the commencement of entry time or entry of the valid user code.

Remote signalling Input and Outputs

These outputs are not applicable to the Optima compact G3 panel.

These terminals have been provided for connection to remote signalling equipment such as a digital communicator, Red Care STU or speech dialler.

Note: The operating polarity of the Communicator output terminals are programmable.

L/FAIL This is a telephone line fail input which is held at approximately 6V by the panel circuitry. The input is activated when pulled to 0V by the telephone line fault output of the communicator. This is usually a voltage free relay or open collector transistor.

When a telephone line fault occurs in the Day mode the panel provides an audible double beep every 10 minutes. This indication is automatically cleared when the fault is removed.

A telephone line fault which occurs while the system is Set will not cause an alarm condition but any external siren (bell box) delay which is programmed will be cancelled and any intruder alarm which is triggered will operate instant sounders.

13V 0V These terminals provide a 13V supply for the communicator up to a total load of 200mA. The output is protected by a 250mA thermal fuse. If this fuse operates it may be reset by removing the load and allowing a few seconds for it to recover.

OUTPUT PORT By default these outputs are programmed as active low output. They are held at 13V and fall to 0V when active, it can source or sink 10mA. The output polarity can be programmed.

These outputs would normally be connected directly to the input channels of wire in type communicators and STUs.

Alternatively each output can be used to drive a relay (coil resistance > 1200 Ω) connected between the output terminal and the 13V supply terminal. The relay will energise when the output port operates. It is recommended that a back EMF protection diode is used in parallel with the relay coil.

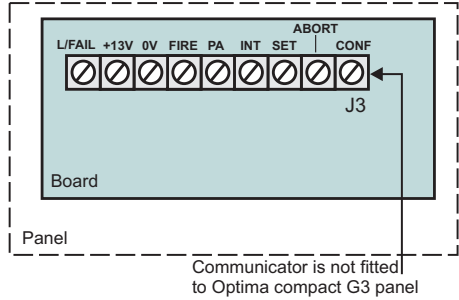

FIRE The fire output operates when the fire zone is triggered.

PA The PA output operates when a PA alarm is triggered or a duress code is used.

INT The intruder output is operated when an intruder condition is triggered whilst the system is set.

SET The Set output operates whenever the system becomes set and is used to indicate opening and closing.

ABORT Operates when an intruder alarm condition is switched off.

CONF The confirmed alarm output operates when 2 independent zones are activated during the same alarm condition.

Important Notes

- a. Each output has been configured as active low and will normally require the EPROM or NVM for the communicator or STU to be programmed as active low or positive removed. However there may be differences between some pieces of equipment and some Alarm Receiving Centres (ARCs).
- b. Where the communicator is powered from an external source, not the panel and the outputs are being used without relays, the panel and external power supply will require a commoned negative supply rail.
- c. If the communicator is not fitted inside the panel and abort is being used, care should be taken to ensure that the abort connection cannot be damaged or severed as this could cause the ARC to incorrectly filter an alarm signal.
- d. It is very important that communicating systems are fully tested and that all signals are correctly received at the ARC when the system is installed and serviced.

Filtering of Intruder alarms

A condition of most police Force Policies and under the guidance of NACOSS NACP 14 (Code of Practice for intruder Alarm Systems Signalling to Alarm Receiving Centres) is that all intruder alarm signals received by an Alarm Receiving Centre (ARC) must be filtered to establish their validity before passing to the police.

The exact method of filtering should be decided according to the regional Police Force Policy and ARC procedures.

In general, the panels offer the following methods which could be used to filter an alarm.

Set/Unset A Set or Unset signal which is received by the ARC at around the same time as an intruder signal can be used to filter the alarm.

Abort Output The abort output operates whenever a user code is entered or a keyswitch is used to switch off an intruder alarm condition. When an abort signal is received by ARC at or around the same time as an intruder signal, the alarm can be filtered.

Restore of the Intruder Output The intruder alarm output is restored to 12V whenever a user code is entered or a keyswitch is used to switch off an intruder alarm condition. Where an intruder alarm is shortly followed by a restore at the ARC, this can be used to filter the alarm.

Factory set condition

User code 1 - - - - - 0123
 User code 2 - - - - - Not programmed
 Duress Code - - - - - Not programmed
 Engineer Code - - - - - 9999
 External siren *Bell* Duration 20 minutes
 External siren *Bell* Delay - - No delay

Program 1

Zone 1 - - - - - Timed
 Zone 2 - - - - - Time Inhibited
 Zones 3...8 - - - - - Immediate
 Exit time- - - - - 30seconds
 Entry - - - - - 30seconds
 Exit mode - - - - - timed

Program 2

Zone1 - - - - - Timed
 Zone 2 - - - - - Time inhibited
 Zone 3...8 - - - - - Immediate
 Exit time- - - - - 30seconds
 Entry time - - - - - 30seconds
 Exit mode - - - - - Disabled

Program 3

Zone 1 - - - - - Timed
 Zone 2 - - - - - Time Inhibited
 Zone3...8 - - - - - Immediate
 Exit time- - - - - 30seconds
 Entry time - - - - - 30seconds
 Exit mode - - - - - Disabled

Security Zones - - - - - Zones 1...8
 Standard Fire zones - - - - - None programmed
 24 hour Fire zones - - - - - None programmed
 Push to set zones- - - - - None programmed
 Keyswitch zones - - - - - None programmed
 Double Knock zones - - - - - None programmed
 Omit prevent zones- - - - - None programmed
 Zone debounce period - - - - 300mS ALL zones

Flag A

Silent PA - - - - - No
 RKP PA Enable - - - - - Yes
 Engineer Reset- - - - - No
 Anti Code Reset - - - - - No
 Door bell on push to set - - No
 Single key setting - - - - - No
 Strobe on setting - - - - - No
 External siren *Bell* on Fire - No

Flag B

Note: The entries marked # are not applicable for Optima compact G3 panel.

#Communicator Output
 active high - - - - - No (active low)
 #Line Fail
 active high - - - - - No (active low)
 User Reset PA - - - - - No
 User Reset Fire - - - - - No
 #Program 1 to report - - - - - Yes
 #Program 2 to report - - - - - Yes
 #Program 3 to report - - - - - Yes
 Rearm counter - - - - - 3 (re-arms)
 Service counter - - - - - Off
 Site Code - - - - - 00

Light Controller

Light Threshold - - - - - 50%
 Light Hold Time - - - - - 30 seconds
 Light Channel 1 - - - - - No zones assigned
 Light Channel 2 - - - - - No zones assigned
 Light Channel 3 - - - - - No zones assigned
 Light Channel 4 - - - - - No zones assigned
 Light Channel 5 - - - - - No zones assigned
 Light Channel 6 - - - - - No zones assigned
 Light Channel 7 - - - - - No zones assigned
 Light Channel 8 - - - - - No zones assigned

First Power up

Before power up, for Optima compact only - fit the top cover on to the base and connect the speaker wires. Leave the cover in position throughout the reset of the installation.

- Check that the factory fitted links are connected to terminals PA, TAMP and T-A.
- Fit the battery wires to the BATT terminals on the Board, Red to + and Black to -.

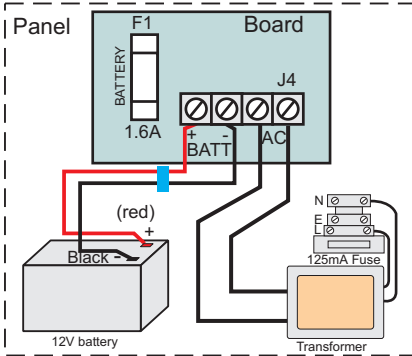

- On connecting the battery the system will now go into alarm condition and Tamper is indicated



Tamper

and there is an audible

indication.



Alarm.

- Fit the cover to hold down the tamper spring at the bottom centre of the board.
- Enter the user code, press **0 1 2 3** (factory set code). The alarm condition will cease and the system will go to Day mode  Day.
- Immediately enter the engineer code

Press **Prog 9 9 9 9**.

The system is now in *Engineer program mode* and can be programmed. Note the



Tamper

Tamper indicator is lit.

Note: The G3 range of panels are **not supplied with wire links** for unused zones. All unused zones must be programmed out by setting them to *disabled* using the **Zone Type** function see page 18.

Mains Connection

The mains power should be connected using a 3 core cable of not less than 0.75mm sq. from a fused spur to the mains connector inside the control panel. The 2 A fused spur must be located close to the control panel.

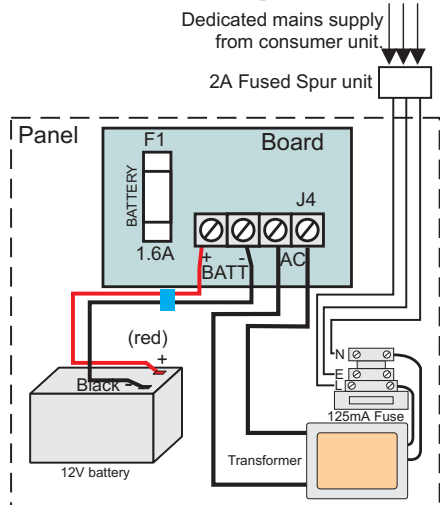

Note: The mains supply must be connected by a technically competent person and according to current IEE regulations.

Caution: To avoid the risk of electrical shock you must always totally isolate the mains supply before opening the control panel cover(s).

- Mains Input Fuse rating: 125mA, 250V type T (anti surge) and of a type approved to IEC 127 part 2 sheet III.

On connecting the mains supply to the panel the power indicator is lit.



Power

Testing the system

Complete the wiring of the system and then:

- Fully test the system and ensure it is fault free.
- Fully program the system
- Fill in the installation log at the back of the manual and retain it for future reference.
- Finally explain the operation of the system to the end user. **The Operating Instructions are attached to the centre of this manual. Detach them and leave them with the user.**

Engineer program mode

The panel may be programmed to suit a wide variety of installations.

Once the *engineer program mode* has been accessed, each configuration may be changed in any order. As each configuration is completed the system will automatically return to top level of *engineer program mode*.

Before entering *engineer program mode* the system should be in the Day mode, with the Day and Power indicators lit.

Key

 LED steady On indication

 LED flashing indication

LED Off

 ARC Output to Alarm Receiving Centre
Communicator outputs are not applicable for Optima compact G3 panel

Internal sound

 Sound description

NOTE: In general a flat beep is an indication of an incorrect key press.

External devices

 Strobe

 External Siren

To exit operation

-  Quit the current function
- Leave program menu
- Down one menu level

System indications

 Day  Power - Unset system indication

 Power - Set system indication

To enter Engineer program mode

Note: The factory configured engineer's access code is 9999. If however this code is changed then enter the appropriate code.



 ZONE 1 - 8
Momentarily On

 Acknowledge

 Tamper Day

To Exit Engineer program mode



 Day

To reset panel to Factory set conditions

Caution: All configurations of the panel are restored to factory 'default' conditions.

Within 5 seconds of powering up the panel

 reset beeps

Access Codes

There are four codes used in the system, all are 4 digit and can be set to any number from 0000 to 9999. The access codes ensure that only authorised users can operate the system.

User 1 and 2 codes

The user 1 and user 2 codes have the same operation for testing, Setting and Unsetting, but user 1 code which is usually considered to be the Managers code has the authority to add, change or delete the user 2 code and duress code.

Duress code

Should be used in a hold up situation where there is pressure to Set or Unset the system. Entry of the code will allow the system to work normally but also generate a silent PA type alarm by operating the PA communicator output. The duress code is not applicable for Optima compact G3 system.

Engineer code

Accesses the Engineer Program mode to allow the system to be programmed. The engineer code will not set or unset the system.

If configured the Engineers access code can be used to reset the system after an alarm.

Note: Entering an invalid user code will operate the code tamper. After **nineteen** incorrect key pushes a full alarm condition will be generated.

Example: To change User 1 code to 3457
Press:

Enter Engineer program mode

8 Codes

Attack

- 1** Change User code 1
- 2** Change User code 2
- 3** Change Duress code
- 9** Change Engineer code

Day

ZONE 1-4

n **n** **n** **n** New code

NOTE - The sounder will produce a flat beep if the code is rejected. The Code is rejected if it is already in use.

Rising beeps

ZONE 1-4

Day

Reset Exit codes Attack

Reset Leave engineer mode

Day Acknowledge Tamper

Zone Type

The G3 range of panels are **not supplied with wire links** to terminate unused zones. Therefore all unused zones must be programmed out by setting them to *disabled* using the **Zone Type** function.

Example: To disable an unused zone 8, Press:



Enter Engineer program mode

5 Zone Configuration

Attack

All Zones

Zone Type

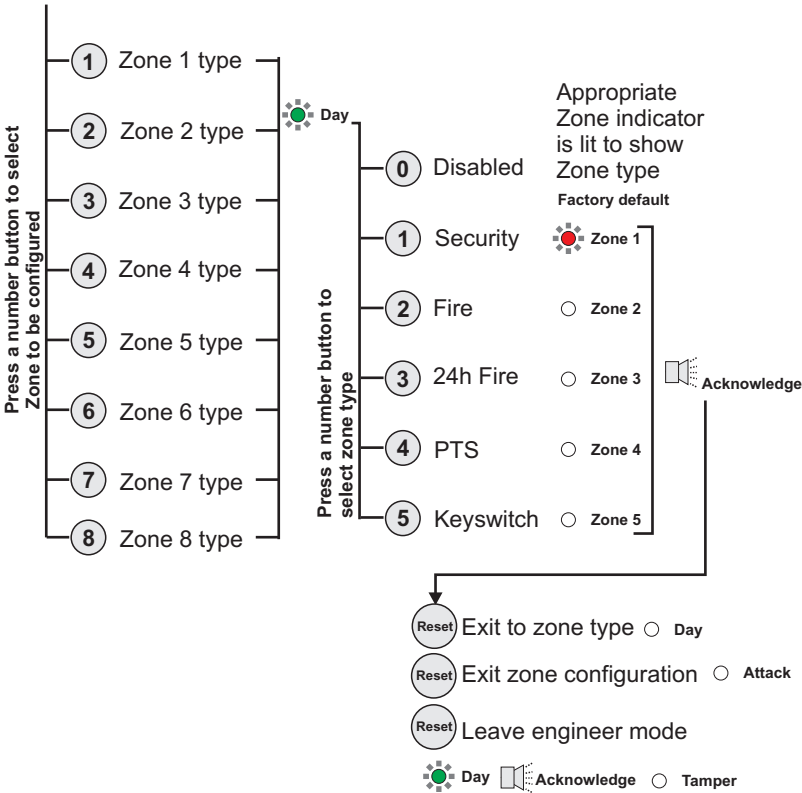

Zone Attributes

Example: To configure zones 4 and 5 for 'Double knock' operation, Press:

Prog 9 9 9 9 6 1 4 5 Reset Reset Reset

Enter Engineer program mode

6 Zone Attributes

Attack

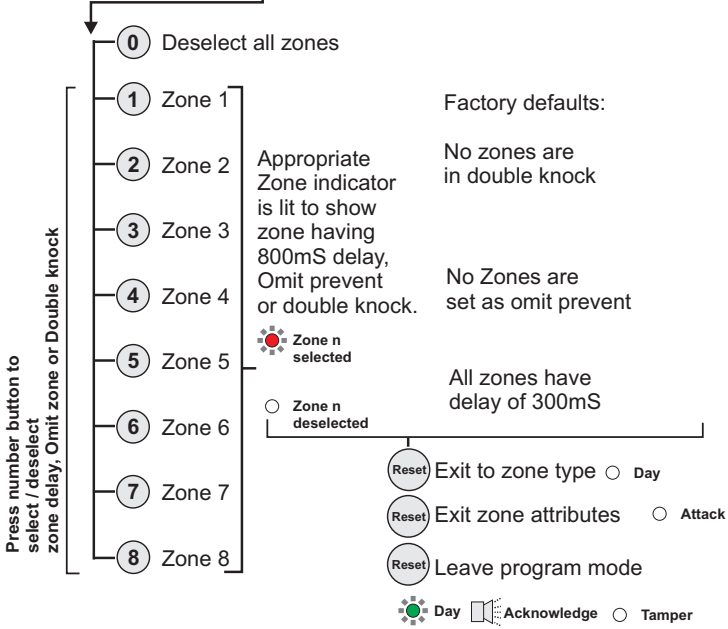
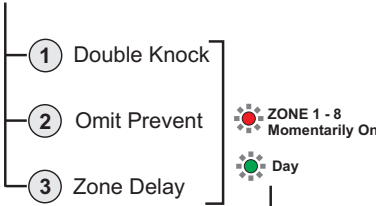

Zone attribute descriptions

Double knock: The panel will require 2 activations of the same detector before causing an alarm condition. This setting is used as a false alarm measure.

Note: Double knock must not be used on zones having magnetic door/window contacts.

Omit Prevent: The panel will prevent the zone from being omitted by the user when setting the system.

Zone Delay: The panel programs a zone delay to 800mS to give extra immunity to false alarms.

Programs

The panel uses 3 Part Set routines known as Programs. In each Program the exit mode can be changed and the zone may be set up to have a different function.

The examples below show how 3 typical Programs could be used in a house.

- Program 1** : To arm all of the zones and become Set as the user leaves the property and closes the final door.
- Program 2** : To protect the perimeter of the property in the evening and become Set after say 20 seconds.
- Program 3** : To protect the downstairs areas of the house at night and become Set instantly and silently.

Note: The above are purely examples. The installer must program the panel to configure all the circuits to the customer's exact requirements.

Exit Modes program

Timed A timed Program will become Set as the Exit timer expires.

Terminated Set

This sets an infinite time out, which will only set once the PTS input is operated.

Final Door A final door program will be Set 5 seconds after a timed zone has opened and closed.

Silent Set This operates exactly the same as 'Timed' but completely silent without the internal sounder signal.

Note: If a program is not selected when the user Sets the system, Program 1 will automatically Set. Therefore Program 1 is usually considered as the Full Set Program containing all of the zones.

Zone Function per Program

Timed : This function would be used to protect the main entry/exit door of the entry route.

Time inhibited : This is a zone which, on setting the panel, allows access to the Entry / Exit zone. However, if the panel is set and an time inhibited zone is triggered before an Entry /Exit zone then an alarm will be generated immediately.

Immediate: This is a zone which will, when entered, go into alarm when the panel is set.

Unused : A zone that is programmed as an Unused zone by the Engineer, then is ignored by the panel. Primarily used for Part set options.

Programs 1,2 and 3

Example: To configure Program 1 Exit mode to Final door set, Press:
 (Prog) (9) (9) (9) (9) (Prog) (1) (6) (3) (Reset) (Reset) (Reset) (Reset)

Enter Engineer program mode

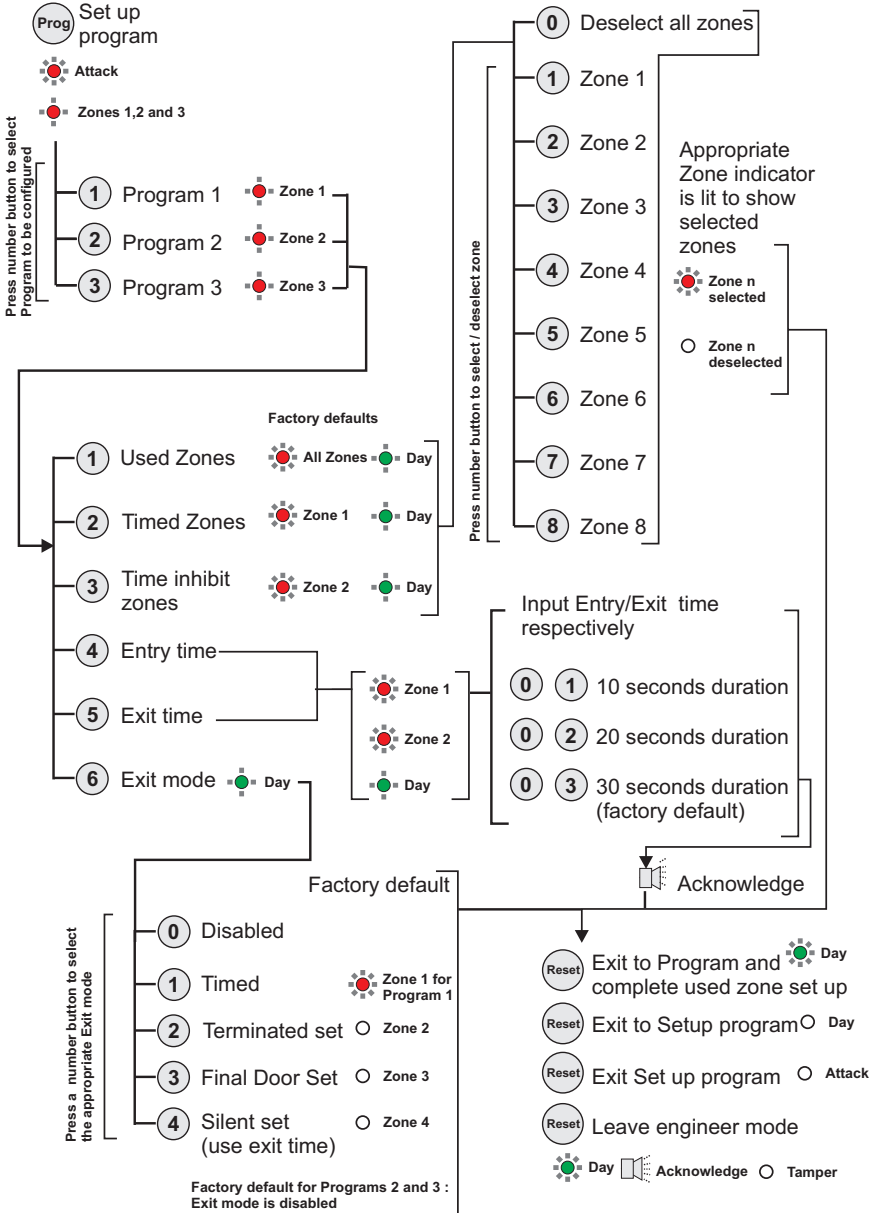

Programs 1, 2 and 3

Alarm and Walk tests

Example: To start bell test and thereafter to stop bell test.
 (Prog) (9) (9) (9) (9) (1) (3) (0) (Reset) (Reset)

Enter Engineer program mode

(1) Alarm test



Press zero to turn off options 2,3,4 and 5 before selecting a new one

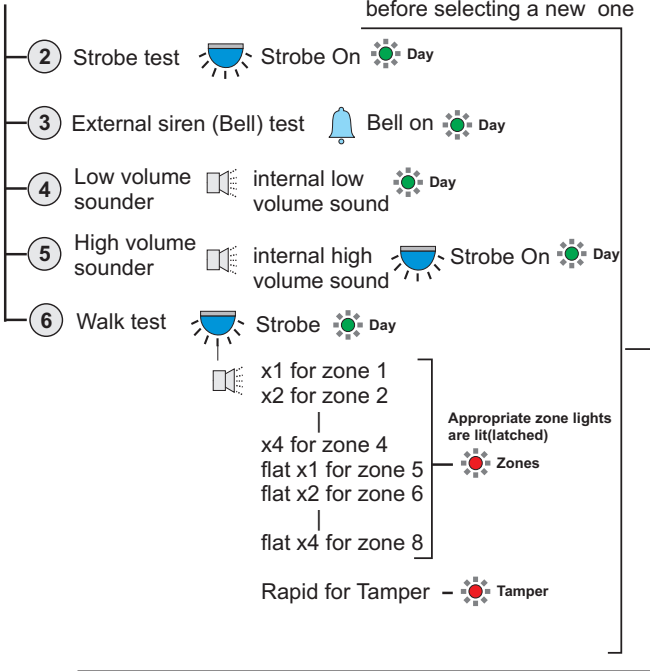

(0) OFF ○ Day

(Reset) Exit current level ○ Attack

(Reset) Leave engineer mode

(Day) (Acknowledge) (Tamper)

Alarm and Walk tests

The alarm test function allows you to test the Strobe, Siren (*Bell*), Low and High volume sounders of the system.

The walk test function allows each detector to be checked in order to verify that they are functioning correctly.

Communicator tests

Note: These tests are not applicable to Optima compact G3 panel.

Example: To test intruder output and thereafter stop the test.

Enter Engineer program mode

② Communicator Tests

Appropriate Zone indicator is lit to show a selected output

Attack

Factory defaults

- ① Fire Output Zone 1
- ② PA Output Zone 2
- ③ Intruder Output Zone 3
- ④ Open /Close Output Zone 4
- ⑤ Abort Output Zone 5
- ⑥ Confirmed Output Zone 6
- Communicator fault Zone 8

① Stop the tests

Reset Exit current level Attack

Reset Leave engineer mode

Day Acknowledge Tamper

The Zone 8 LED is lit to show there is a communicator line fault.

'Flag A' Options

Example: To set the panel for engineer reset, Press:

Enter Engineer program mode

③ Flags A

Appropriate Zone indicator is lit to show flag setting

Attack

Zones 1-8 Momentarily On

Factory defaults

- ① Silent PA Zone 1
- ② RKP PA enable Zone 2
- ③ Engineer reset Zone 3
- ④ Anti-code reset Zone 4
- ⑤ Enable Door bell on PTS Zone 5
- ⑥ Enable single key setting Zone 6
- ⑦ Enable strobe on setting Zone 7
- ⑧ Enable Bell in Fire Zone 8

Reset Exit current level Attack

Reset Leave engineer mode

Day Acknowledge Tamper

Flag A descriptions:

Silent PA : When this flag is set and on operating PA will cause a Silent PA alarm.

RKP PA Enable: When this flag is set the keypad PA buttons are enabled.

Engineer Reset: When this flag is set an Engineer code must be entered to reset the system after a full alarm. When the flag is clear the system can be reset by the user.

Anti-code Reset: When this flag is set it enables the anti code reset function.

Enable Door bell on PTS: When this flag is set it allows a zone circuit programmed as PTS to operate as a door bell.

Enable single key setting: When this flag is set it allows the panel to be set by pressing the SET button (ie code entry is not needed), however a 4 digit code is needed to Unset the panel.

Enable strobe on setting: When this flag is set the external strobe will flash for 3 seconds once the panel has successfully set.

Enable external Fire Bell: When this flag is set the external siren *Bell box* will sound 2 seconds On / 2 seconds Off during a fire alarm.

'Flag B' options

Note: The following settings: *Communicator output, Line Fail, Program 1, 2 and 3 to report* are not applicable to Optima compact G3 panel.

Example: To set the panel for user to reset PA, Press:



Enter Engineering program mode

4 Flags B Appropriate Zone indicator is lit to show flag setting

Attack

- | | | |
|----------|---------------------------------|------------------------------|
| | Zones 1-8 Momentarily On | Factory defaults |
| 1 | Communicator output active high | <input type="radio"/> Zone 1 |
| 2 | Line fail active high | <input type="radio"/> Zone 2 |
| 3 | User Reset PA | <input type="radio"/> Zone 3 |
| 4 | User Reset Fire | <input type="radio"/> Zone 4 |
| 5 | Program 1 to report | Zone 5 |
| 6 | Program 2 to report | Zone 6 |
| 7 | Program 3 to report | Zone 7 |
| 8 | Entry deviate | <input type="radio"/> Zone 8 |

- Exit current level Attack
- Leave engineer mode
- Day Acknowledge Tamper

Viewing the event log

Example: To view up to 8 previous events and thereafter to stop the event scroll, Press:

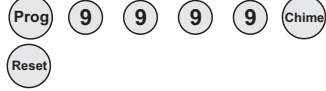

Enter Engineer program mode

View the event log

Tamper
Automatic event scroll
Starting from event 1 to 8

To manually scroll

- 1** View event 1 (newest event)
- 2** View event 2
- 3** View event 3
- 4** View event 4
- 5** View event 5
- 6** View event 6
- 7** View event 7
- 8** View event 8 (Oldest event)
- Resume automatic scroll

Zone, PA and Tamper indicators will be lit to show zone in alarm. Flashing indicates the first zone in alarm. Day indicates status of panel at the time of alarm

Stop event scroll / view Tamper

Leave engineer mode

Day Acknowledge Tamper

Flag B descriptions:

Communicator output active high: When this flag is set it configures the polarity of communicator outputs to active high, that is output is held at 0V rising to 12V in alarm.

Line fail active high: When this flag is set it configures the polarity of line fail input.

User Reset PA: When this flag is set it permits the user code to reset the system after a PA alarm, even if Engineer reset flag is set.

User Reset Fire: When this flag is set it permits the user code to reset the system after a Fire alarm, even if Engineer reset flag is set.

Program n to Report: When this flag is set it allows program n to activate the intruder and confirmed outputs. (Main use is to prevent a night time program from communicating).

Entry deviate: When this flag is set it permits an immediate zone to be activated during the entry period without causing a full alarm.

External siren (Bell box) and Service Timers

Example: To set bell timer for 10 minutes duration, Press:



Enter Engineer program mode

7 Timers and Counters

Attack

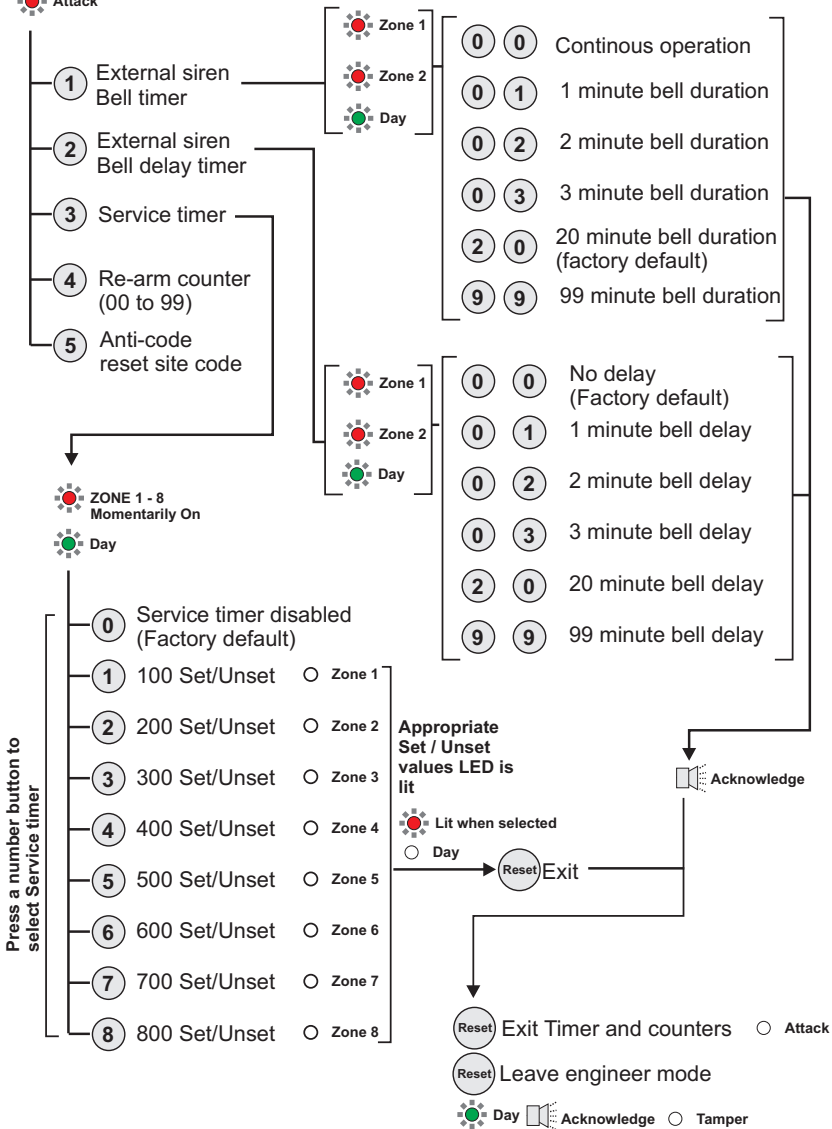

External siren (Bell box) and Service Timers

Re-arm and Anticode reset code

Example: To set panel re-arms to 10 times before panel is shut down, Press:



Enter Engineer program mode

7 Timers and Counters

Attack

- 1 External siren (Bell) timer
- 2 External siren (Bell) delay timer
- 3 Service timer
- 4 Re-arm counter (00 to 99)
- 5 Anti-code reset site code

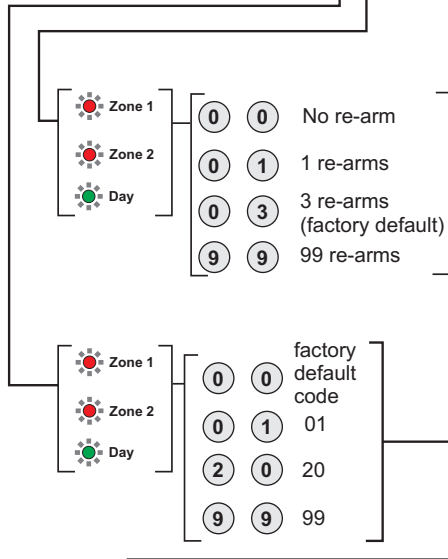

- Acknowledge
- Day
- Exit to Timer and counters Attack
- Leave program mode
- Day Acknowledge Tamper

Re-arm

After an alarm the panel will automatically reset itself when the external siren (bell box) timer has expired. Any zones which still remain open at that time will be omitted automatically.

Note: By default there are 3 automatic re-arms before the panel is shut down.

Anti code reset (Engineer reset)

If the system has been programmed to be engineer reset, after an alarm it will lock out and the RKP will continually display the cause of the alarm. The engineer would then be required to attend the site and use the engineer code to reset the system.

Where anti-code reset has also been enabled, the RKP will still show the alarm cause and also display a 4 digit 'quote code' by sequentially flashing zone indicators 1-8.

At this point the end user would contact the engineer. After determining the cause of the alarm and deciding that a engineer call was not necessary, a 6 digit anti-code would be given to the user which would reset the system.

This anti-code is generated from a small computer program which is installed at most UK Alarm receiving Centres (ARC), or alternatively can be run on a PC by the engineer.

Security of the anti-code reset system is maintained by a 2 digit site code which is set up in the anti-code generator programme. The same 2 digit site code must also be set up in the control panel during installation.

Lighting controller

Example: To assign zones 1 and 2 to lighting controller channel 1, Press:



Enter Engineer program mode

9 Lighting Controller

Attack

All Zones

To assign zones to channel press to select and again to deselect zone (Factory default: No zones are selected)

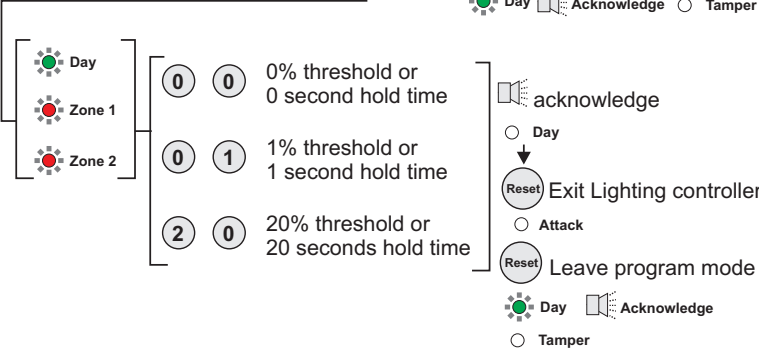
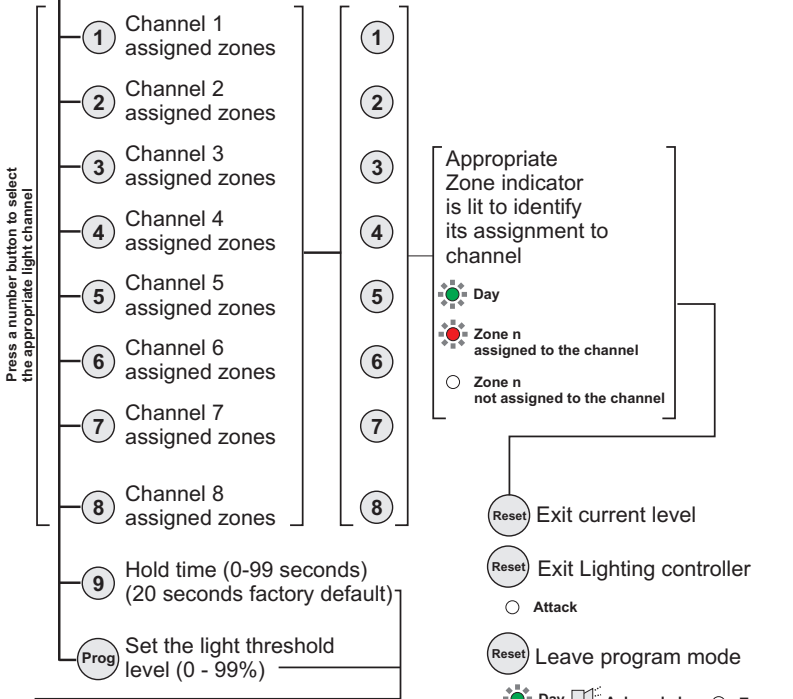

Lighting controller

Faults

Fault conditions are often the result of minor installation errors or misinterpretation of the equipment being installed. The following points outline the most common installation and commissioning faults.

- a. As supplied the user code is 0123 and the engineer code is 9999. Both codes will revert back to these default settings on clearing the NVM.
- b. The Engineer Program is accessed directly from Day mode via the engineer code.
- c. If a tamper, PA or 24Hr fire fault is present on the system, it will go to a lock out condition (showing the appropriate indication). The keypad will not produce any audible responses and the system will not operate until the fault has been found and rectified.
- d. The most common cause of a zone not responding to detection is incorrect wiring. Normally closed detectors must be wired together in a series loop before connecting into the appropriate ZONE terminals. Tamper are series wired in the same manner.
- e. Where a permanent zone fault is showing and the loop resistance is found to be in order, the most probable cause is a short circuit between the zone wiring and the tamper wiring. When measured with a multimeter the series resistance between the zone and tamper wiring should be infinitely high.
- f. If totally lost as to the cause of a fault, remove ALL wiring from the Board. Refit the 4-links and test the system. Never fit links to any positions other than those marked on the Board.

- g. Before testing or replacing any fuses, ALL power must be removed. Fuses which fail continually are almost certainly the result of a short circuit or low resistance across the 13V supply or external siren (bell box) supply (terminal D).

Whenever working close to the mains supply or connector, you should exercise extreme caution. Always isolate the mains supply before removing the control panel covers.

Where normally open and closed detectors are being used these must be wired to a zone in the manner shown.

The example below shows how to wire normally open detectors on zones 3.

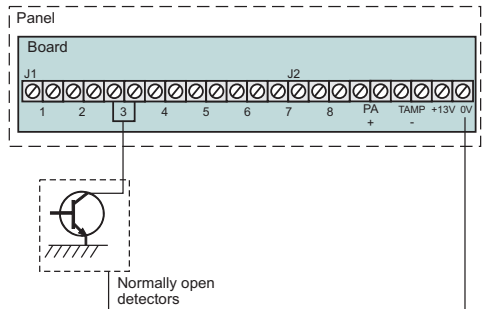

The example below shows how to wire normally open detector on zones 3 and a normally closed detector on zone 4.

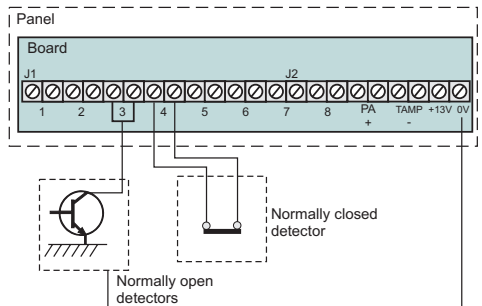

- h. Where **Pressure mats** are being used these must be connected to a zone in the manner shown. The example below shows pressure mats connected to zones 3.

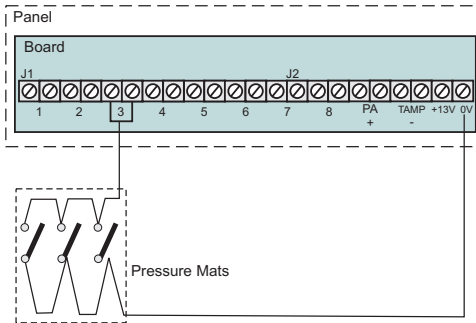

Specification

Indicators on Control panel or RKPs	Zone 1-8, Power, Attack, Tamper and Day
8 Zones	+ve loop, programmable function in each program
Tamper	-ve loop, internal sounders in Day – Full alarm in Set
PA	+ve loop, always active
External siren (Bell box) Output	12V, adjustable timer (1-99 mins) or continuous
Strobe Output	12V latching
Extension Speaker	16 Ω (2 maximum) 130mA each
Exit/Entry timers seconds	Programmable (10-99 seconds)
Zone Input Delay	300 or 800mS
Set +ve Output	0V in Day (sinking 40mA) 12V in Set (Sourcing 10mA)

Current Consumption Control panel	Standby 80mA Alarm 250mA
Current consumption RKP	Standby 40mA Alarm 70mA
Low voltage output	13.8V dc stabilised (5%) up to 350mA
Rechargeable Battery	Accenta/Optima G3 mini/compact - 12V, 1.2 or 2.1Ah Accenta/Optima G3 - 12V, up to 7Ah
Charge Voltage	13.8V dc (5%)
Board Fuses	1.6A & 1A 20mm quick blow
Mains Input fuse	125mA, 250V type T (anti-surge) type approved to IEC 127, part 2 sheet III
Total Current Output	1A when supported by a fully charged battery
Mains Supply Voltage	230V (10%) 50Hz max load 0.2A
Ambient Operating temperature	0 C to 40 C
Enclosure construction	3mm Polycarbonate
Dimensions	Accenta/Optima G3 mini/compact H 200mm W 253mm D 55mm Accenta/Optima G3 H 230mm W 290mm D 80mm RKP H 85mm W 122mm D 28mm

Index

I

13V Supply 11
 24 hour fire zone . 2,8,14,18
 3 Part Set 20

A

AC terminals 3
 Access Codes. . . . 17
 Alarm test 22
 Anti Code Reset . 14,23,26
 ARC 13

B

Battery 15,29
 Bell in fire 23
 Board 4
 BS 4737 1986/87. 1

C

Charge Voltage. . . 29
 Chime 2
 Codes. 2
 Communicator . . . 23
 Communicator
 Outputs 12,14
 Current
 Consumption . . . 29

D

Day mode 15
 Detectors 3
 Dimensions. 29
 Door bell 14,23
 Double knock . . . 14,19
 Duress Code . . . 14,17

E

Engineer Code . . . 14,17
 Engineer
 program mode . . . 16,28
 Engineer Reset . . 14,23
 Entry deviate . . . 24
 Entry time 14,21
 Event log 24
 Exit Mode 14,20,21
 Exit time 14,21
 Exit/Entry
 timers 29
 Extension speakers 9
 External bell
 on Fire 14
 External siren
 (Bell) Delay . . . 14
 External siren (Bell)
 Duration 14
 External siren
 (Bell) Output. . . 29

External siren
 (bell) test. 22
 External siren
 (Bell) timer 25
 External siren -
 Bell- Output 10

F

Factory set
 conditions 14,16
 Faults. 28
 Final door set. . . 20,21
 Fire zone 8,18
 Flag A 23
 Flag B 24
 Full Set. 20
 Fuses 4,28

H

High volume
 sounder test. . . . 22
 Hold time. 27

I

Immediate zone . 20

K

Keypad zone . 14,18

L

light channel . . . 27
 Light Hold Time . 14
 Light threshold . . 14,27
 Lighting controller 2,14,27
 Line Fail 14
 Local Authorit . . 3
 Low volume
 sounder test . . . 22

M

Mains. 15,29
 Managers code . . 17

N

NACOSS. 7,13
 NACP 14. 13
 Normally closed
 detectors 28
 normally open
 detectors 28
 NVM 2,13

O

Omit prevent . . . 14,19
 Operating
 temperature . . . 29

P

PA 2,8,29

PA fault. 28
 Pressure mats. . . 29
 Program 1 14,20
 Program 1
 to report 14,24
 Program 2 14,20
 Program 2
 to report 14,24
 Program 3 14,20
 Program 3
 to report 14,24
 Programs
 1,2 and 3 21
 PTS zone 2,18
 Push to Set 7,14

Q

Quick set 2
 quote code 26

R

Re-arm 26
 Rearm counter . . 14
 Red Care STU . . . 2,12
 Remote keypad. . . 2,5
 Remote keyswitch 7
 RKP 3,5,14,29
 RKP PA enable. . 23

S

Security Zones . . 6,14,18
 Service counter. . 14
 Service timer . . . 25
 Set 11
 Set system 16
 Silent PA 14,23
 Silent Set 20,21
 Single key setting 14,23
 Site Code 14
 Speakers 3
 Specification . . . 29
 Standard Fire zone 8,14
 Strobe on setting . 14,23
 Strobe test 22

T

T A D B 10
 Tamper 29
 Tamper fault . . . 28
 Tamper network . 8
 Terminated Set . . 7,20,21
 Time inhibited
 zone 20,21
 Timed. 20
 Timed exit 21
 Timed zones . . . 21
 Total current . . . 3

U

Unset system 16
 Unused zone 20,21
 User code 1 14
 User 1 2
 User 1 and 2 codes 17
 User 2 2
 User code 2. 14
 User reset fire . . . 14,24
 User reset PA. . . . 14,24

V

Volume 9

W

Walk Test 2,22
 wire links 4

Z

Zone Attributes. . . 19
 Zone debounce . . 14
 zone delay 19
 Zone Input Delay. 29
 Zone Type 18

Servicing organisation Details

Servicing organisation name:

Telephone number:

Date of installation:

Account Number:

Parts

Below is a list of approved parts and accessories.

- 8SP 401 Accenta G3 panel
 - 8SP 400 Accenta mini G3 panel
 - 8EP 395 Optima G3
 - 8EP 396 Optima compact G3 panel
 - 8EP 219 Accenta LED RKP
 - 8EP 332 Accenta LCD RKP
 - 8EP 336 Accenta Speech Dialler
 - 8EP 276 Informa
 - 8EP 289 Extension Speaker
 - 8EP 372 Opti-Cam Lighting Controller
- A range of detectors are also available, for more information contact your supplier.

	Resistance	Area protection and equipment used (eg PIR, Contacts..)
Zone 1		
Zone 2		
Zone 3		
Zone 4		
Zone 5		
Zone 6		
Zone 7		
Zone 8		

Quick Reference

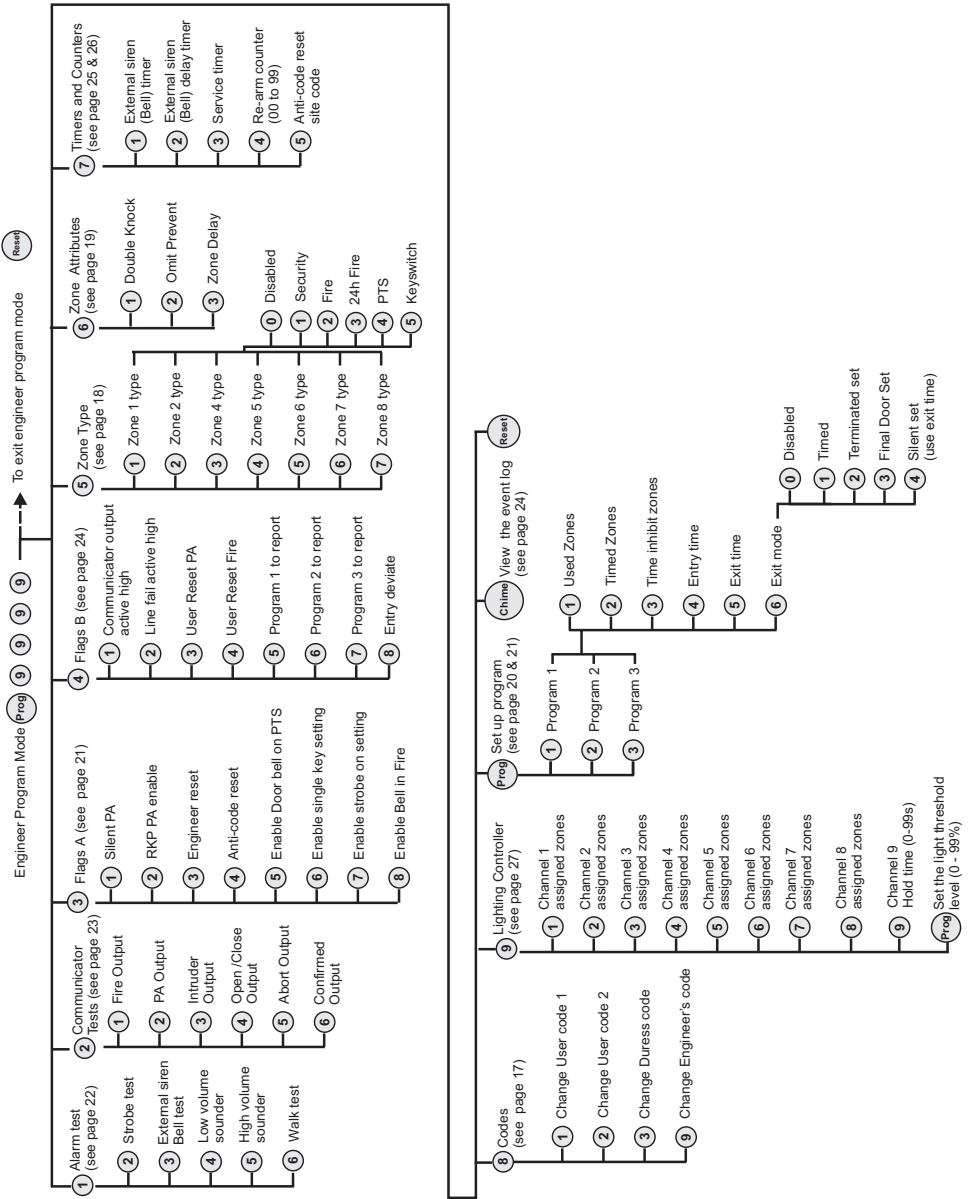

The panels conform to the requirements of the European EMC and Low Voltage directives, and carries the CE mark.

For Technical Support



: 01268 563270



Intruder alarm system

Operating Instructions

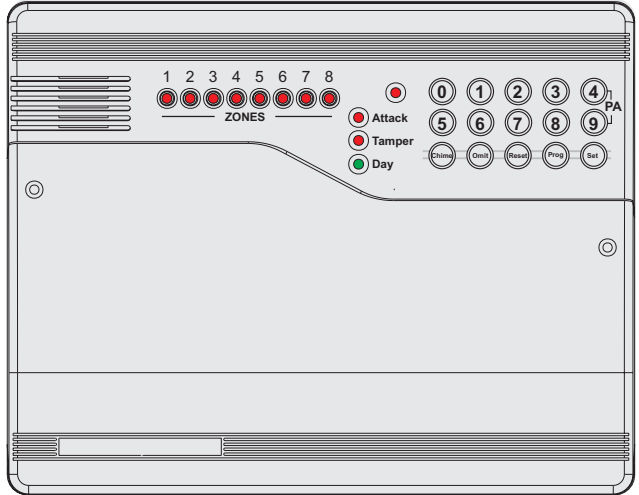
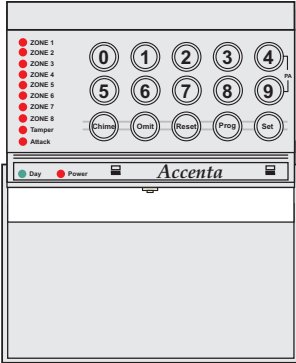

Servicing organisation (Installer) name: _____

Telephone number: _____

Date of installation: _____

Account number: _____

Installation date: _____

System installation

This booklet tells you how to operate your intruder alarm system. To simplify this booklet we have assumed that the alarm system has been installed by a professional intruder alarm system installer (the installer), and that the system is operated in a “typical” way. Aspects of your system that are not “typical” will be described by your installer.

Note: If you have any questions about your intruder system, then consult your installer, see contact details on the front page.

Codes

To operate the alarm system you will need to use a code. A code is 4 digits long, and can be any number from 0000 to 9999. By default the code is 0 1 2 3 but you should change this as soon as possible.

Alarm System Operation

This booklet describes two versions of the alarm system. The **Optima** version has the keypad and indicators on the main control panel. The **Accenta** version has the keypad and indicators on a small remote keypad. You operate the alarm system by pressing buttons on the keypad and viewing the indicators. Both alarm systems work the same way. Both **Accenta** and **Optima** systems can be fitted with an optional remote keypad.

Personal Attack

If you are under threat, or are being attacked, you can activate the alarm by pressing the **4** and **9** keys at the same time on any keypad. The alarm system will produce a loud alarm sound, and the external siren will be turned on.

Fire Zones

One or more Zones on your alarm system may have a Fire or Smoke detector connected to it. In the event of a fire the alarm system will produce a distinctive two-tone fire alarm sound, and the outside siren will pulse 2 seconds on, 2 seconds off. You should leave the premises immediately, and only re-enter when it is safe to do so. The alarm can be silenced by entering your code.

Power Indicator

The **Power** indicator on the control panel or keypad will light whenever the mains power supply is present. If mains power fails then the **Power** indicator will go out, but the system will run from its backup battery for several hours. If the **Power** indicator goes out when mains power is present then a fault may have developed on your system and you should contact your installer.

Warning beeps

Your system may produce warning beeps to inform you of a potential problem. A single beep every 10 minutes tells you that the system needs to be serviced. You should call your installer to arrange a service visit. The system will continue to operate correctly in all respects.

A double beep every 10 minutes tells you that the telephone line that the alarm system uses is not available or has failed. This may be due to someone using a telephone on the same line. If this problem persists you should contact your installer to rectify the problem. Your alarm system will continue to operate, but it cannot send alarm messages via the telephone line.

Signalling Device

Your alarm system may have been fitted with a signalling device. This device uses the telephone line to send an alarm message to an Alarm Receiving Centre in the event of an alarm. The operator at the ARC may request the police to attend your premises.

How to set the system

When you leave your premises you will need to set (or turn on) the intruder alarm system.

1. Before setting the system you should ensure that the premises have been completely vacated and that all doors and windows are closed. Ensure that pets do not have access to the protected areas as they can cause a false alarm.

The green **Day** indicator should be lit.

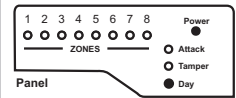
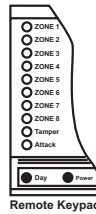

2. Enter your **code** 0 1 2 3 and check that the system is clear (none of the zone indicators are lit).

The system will now produce an exit beep tone. You should leave the premises by the exit route recommended by your installer. The system will set when the exit beep tone stops.



3. The **Day** indicator will go out. You should wait until you hear that the exit beep has stopped before assuming that the system has set.

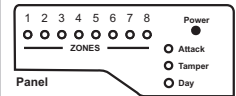
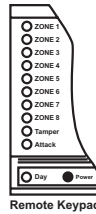

How to Unset the system

When you enter your premises you will need to unset (or turn off) the system.

1. Enter your premises by the route recommended by your installer. The system will produce an entry beep tone.

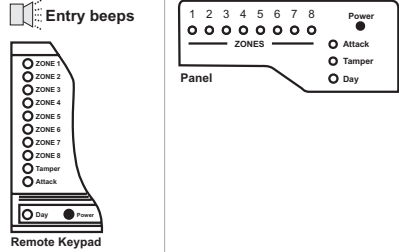

2. Key in your code **0** **1** **2** **3**, and the entry tone will stop. The green **Day** indicator will light.

If any Zone, Tamper or Attack indicator lights up then an alarm has occurred, and an intrusion may have taken place. Seek assistance before investigating further as intruders may still be on the premises. Then reset the system (refer to page 7).

Note that when you enter your premises you will have a short period of time, usually 30 seconds, to key in your code. If you fail to do this the system will go into alarm. Key in your code to stop the alarm.

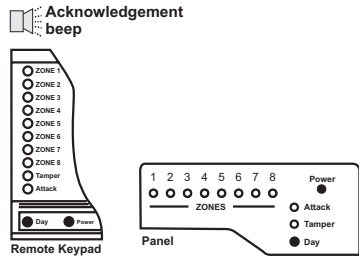

How to part set the system

If your installer has programmed your system for **part set** operation you will be able to set some zones of the system while others remain unset. Part set operation is often used at night time, and it will permit you to freely walk around the bedrooms while the living area and outside doors are protected. Your system may have 2 part-set programs called Program 2 and Program 3.

- Before part-setting the system you should ensure that all doors and windows are closed. Ensure that pets do not have access to the protected areas. Your installer may have instructed you to use a different keypad to the one normally used to set the system.

The green **Day** indicator should be lit.

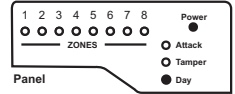
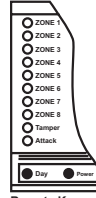

- Enter your **code** 0 1 2 3. The Exit beep will start.



- Press the **Prog** key. The exit tone will stop and Zone indicators 1 to 3 will light.

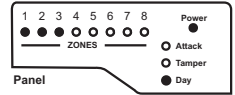
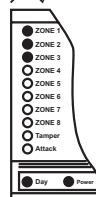

- Press 2 or 3 to select part-set program 2 or 3. You must now leave the protected zones. The system will set after a short time.



Note: There will be no exit beeps if **silent set** exit mode was programmed.

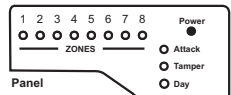
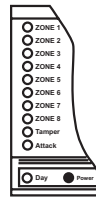

How to silence an alarm

If your system goes into alarm then be aware that intruders may be in the premises. Seek assistance before investigating the cause of the alarm.

1. Enter your code **0** **1** **2** **3**.

The alarm will stop, and the Zone, Tamper or Attack indicators will light to show the cause of the alarm. When 2 or more indicators are lit, the flashing indicator shows the first alarm, and the steady indicators show the second and subsequent alarms.

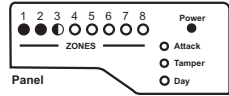
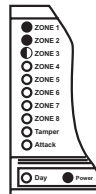

3. You may need to cancel Police response. Your installer will provide details of how to do this.

You will now need to reset the system, as described in the following section.

How To Reset After An Alarm

After any alarm you will need to reset your system so that it can be used normally. Your installer may have programmed the system to be reset by you, the installer, or by Anti-code.

- Press the  key.

If the Zone, Tamper or Attack indicators all go out and the **Day** indicator lights then the system has been reset.

If any of the indicators continue to flash then the system has been programmed to be reset by the installer. In this case you must call the installer to reset the system.

If all indicators light steady (not flashing), and the keypad stops working, then the system has entered a fault-lockout. You must call the installer rectify this fault.

 Strobe Off

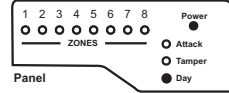
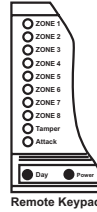

Anti code reset

The installer may instruct you to reset the system by an Anti-code.





- Press . The system will now display a sequence of 4 numbers by using the Zone indicators. Each number will be displayed for a few seconds, the system will beep, and display the next number. You can repeat this sequence by pressing **Reset** again. Write down the 4 digit number and quote it to the installer
- The installer will tell you a 6 digit anti-code.
- Key in the 6 digit code to reset the system.

 Call your installer for the **anti-code**.

Operating instructions

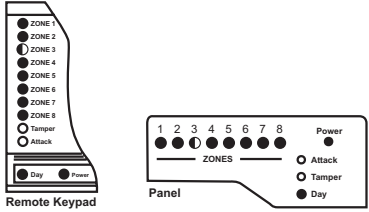

How to Omit zones

If you cannot set the alarm system because a detector is faulty and in constant alarm you may need to omit its zone from the alarm system. A zone which has been omitted cannot cause an alarm.

1.	Key in your code to start the exit procedure. For more information see How to set the system or How to set program 2 or 3.	 Exit beeps
2.	Press Omit and the exit beep tone will stop, and the indicators will display all zones being used.	 Exit beeps
3.	Press the zone numbers to be omitted (n), these indicators will now flash. If a flat reject tone is produce then the zone cannot be omitted.	 Remote Keypad: ZONE 1, ZONE 2, ZONE 3, ZONE 4, ZONE 5, ZONE 6, ZONE 7, ZONE 8, Tamper, Attack, Day, Power. Panel: 1, 2, 3, 4, 5, 6, 7, 8, ZONES, Power, Attack, Tamper, Day.
4.	When you have finished press Set to set the system.	 Exit beeps  10 seconds insistent beeps

How to Quick Set the system

When you set the system you will usually have about 30 seconds to exit the premises. This also means that you need to wait 30 seconds for the system to set. You can reduce this time to just 5 seconds by carrying out a second 'set' a Quick Set.

1.	Key in your code to start the exit procedure. The exit beep tone will start. For more information see How to set the system, or How to set program 2 or 3.	 Exit beeps
2.	Press Set to Quick set the system and the exit beep tone will change to a faster, insistent, tone. The system will set in 5 seconds, and the exit tone will stop.	 5 seconds insistent beeps

How to set up Chime Zone

Chime is a low security facility for use when the system is unset. It is particularly useful in a shop to warn of customers presence, or in a house to warn when a back door has been opened. When a Chime zone detects movement the system will produce a brief two-tone sound, and the Zone indicator will light.

To set any Zone to Chime:

1. The green **Day** indicator should be lit.

Press the **Chime** button, and the system will produce a brief chime tone, the **Day** indicator will flash, and the Zone indicators will light to show those Zones that are already set-up for Chime (possibly none).

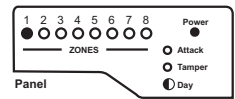
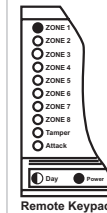

2. Momentarily press the number of the zone to toggle it in and out of chime.

For this example we have Zone 1 in chime and we want to de-select Zone 1 chime and select Zones 2 and 3 to chime.

Press **1** **2** **3**.

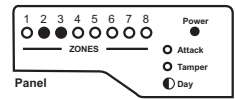
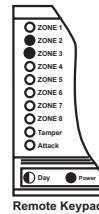

3. When you have finished using the Chime mode press **Reset**.

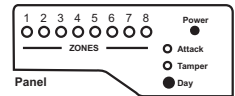
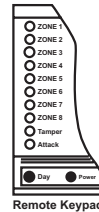



Operating instructions

How to change your User code

You should change your main code regularly to prevent potential intruders from knowing your code.

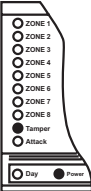
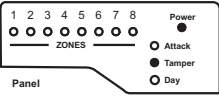
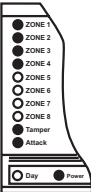
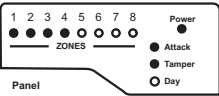
All codes are 4 digits long. The factory set main code is **0 1 2 3** but this may have been changed.

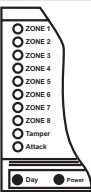
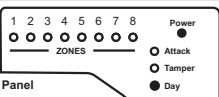
1.	Press Prog and now enter your code 0 1 2 3 . The Tamper indicator will light and the Day indicator will go out to indicate that you are in Programming mode.		
2.	Press 8 to select user code reprogram. The Attack and Zone indicators 1 to 4 will be lit to prompt you to enter a new code.		
3.	Key in your new code n n n n .		
4.	If the code is accepted the system will produce a series of rapid beeps. If the code is rejected, for example if it is already in use, the system will produce a flat reject tone. You must go back to step 2.	 Rising beeps	
5.	Press Reset to exit programming mode. The Tamper indicator will go out and the Day indicator will light.		



Example

If your code is 0123 and you wish to change it to 5678 then:

Press **Prog** **0 1 2 3** **8** **5 6 7 8** **Reset**.

How to change your second code

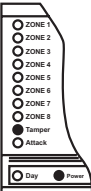
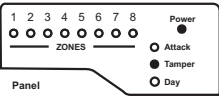
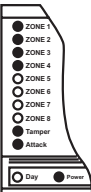
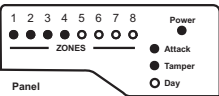
Your alarm system can have a second user code. You may find it useful to set-up this second code for use by a neighbour for use when you are on holiday. The second user code operates like your user code, but it cannot be used to change or delete your code.

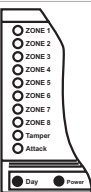
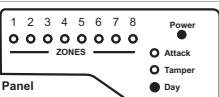
<p>1.</p>	<p>Press Prog and enter your code 0 1 2 3. The Tamper indicator will light and the Day indicator will go out to indicate that you are in Programming mode.</p>		
<p>2.</p>	<p>Press 7 to select second code reprogram. The Attack and Zone indicators 1 to 4 will be lit to prompt you to enter a new 4 digit <i>user code</i>.</p>		
<p>3.</p>	<p>Key in the new second code n n n n.</p>		
<p>4.</p>	<p>If the code is accepted the system will produce a series of rapid beeps.</p> <p>If the code is rejected, for example if it is already in use, the system will produce a flat reject tone. You must go back to step 2.</p>		
<p>5.</p>	<p>Press Reset to exit program mode. The Tamper indicator will go out and the Day indicator will light.</p>		

Example

If your second code is 1234 and you wish to change the code to 7890, then:

Press **Prog** **1** **2** **3** **4** **7** **7** **8** **9** **0** **Reset**.



How to delete your second code

You can delete the second code to prevent it from being used.

- Follow steps 1 and 2 of **How to change your second code** and press **Omit**.
- Follow steps 5 of **How to change your second code**.

How to change the Duress code

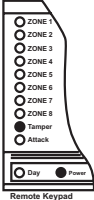
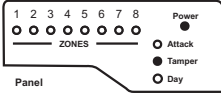
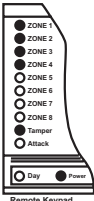
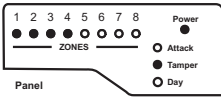
Your alarm system can have a duress code. The Duress code is used in a hold-up situation where there is pressure to set or unset the system. The Duress code operates like your normal code but in addition it will silently send a signal to the Alarm Receiving Centre who will inform the Police. The duress code can only be changed by the main user. Note the Duress code facility is not applicable to **Optima compact G3** system.

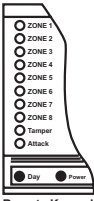
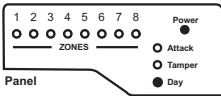
<p>1. Press Prog and enter your code 0 1 2 3. The Tamper indicator will light and the Day indicator will go out to indicate that you are in Programming mode.</p>	 <p>Remote Keypad</p>	 <p>Panel</p>
<p>2. Press 9 to select Duress code programming. The Zone indicators 1 to 4 will light to prompt you for a new code.</p>	 <p>Remote Keypad</p>	 <p>Panel</p>
<p>3. Now enter your new duress code n n n n.</p>		
<p>4. If the code is accepted the system will produce a series of rapid beeps.</p> <p>If the code is rejected, for example if it is already in use, the system will produce a flat reject tone. You must go back to step 2.</p>	 Rising beeps	
<p>5. Press Reset to exit programming mode. The Tamper indicator will go out and the Day indicator will light.</p>	 <p>Remote Keypad</p>	 <p>Panel</p>

Example

If you need to change the duress code to 6543, then:

Press **Prog** **0** **1** **2** **3** **9** **6** **5** **4** **3** **Reset**.

How to view the event log

The event log keeps a memory of the last 8 alarm events.

1. Press **Prog** and enter your code **0 1 2 3**. The **Tamper** indicator will light and the **Day** indicator will go out to indicate that you are in Programming mode.

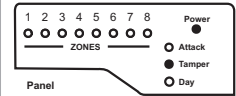
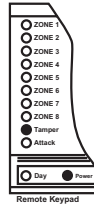

2. Press **Chime**. The system will display 8 alarm events in sequence, with the last (most recent) alarm first. When 2 or more indicators are lit, the flashing indicator shows the first alarm, and the steady indicators show the second and subsequent alarms.

The example here shows an event where **Zone 3** was the first zone in alarm followed by **Zones 1** and **2**.

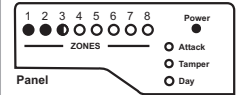
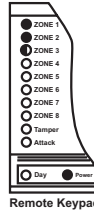

3. All 8 alarm events will be displayed in sequence, with a 5 seconds delay between each event. You can cause the display to pause by pressing **Chime**. You can also display a specific event by pressing its event number, **1** to **8**.

4. Press **Reset** to exit the event log and press **Reset** again to exit program mode. The **Tamper** indicator will go out and the **Day** indicator will light.

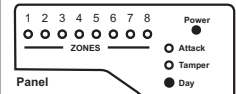
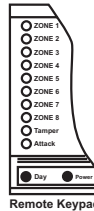

How to test your alarm system

You should check that your alarm system still works correctly by periodically carrying out the alarm system tests described here.

How to test the Strobe, External Siren and Internal Sounders

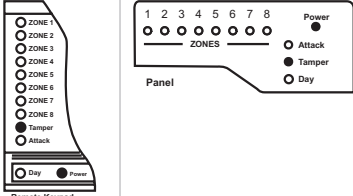
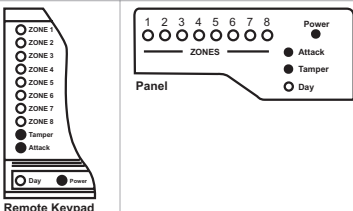
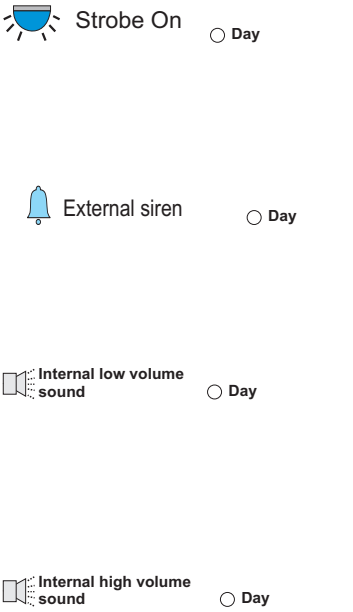
<p>1. Press Prog and enter your 4 digit <i>user code</i> 0 1 2 3. The Tamper indicator will light and the Day indicator will go out to indicate that you are in Programming mode.</p>	 <p>The Remote Keypad shows ZONE 1-8, Tamper, and Attack indicators. The Panel shows ZONES 1-8, Power, Attack, Tamper, and Day indicators. In this step, the Tamper indicator on the keypad and the Day indicator on the panel are shown as lit.</p>
<p>2. Press 0 to select alarm test mode. The Attack indicator lights to indicate that you are in alarm test mode.</p>	 <p>The Remote Keypad and Panel diagrams are identical to step 1, but now the Attack indicator on the keypad and the Attack indicator on the panel are shown as lit.</p>
<p>3. Strobe test</p> <p>Press 2 to test the strobe light. This is normally mounted on the external siren. It should produce a bright flash at a rate of 1 flash every few seconds. Press 0 to stop this test.</p> <p>Siren Test</p> <p>Press 3 to test the external siren, this should produce a loud alarm sound. Press 0 to stop this test.</p> <p>Sounder Low Volume Test</p> <p>Press 4 to test the Low volume sounder. This should produce a low volume alarm sound. Press 0 to stop this test.</p> <p>Sounder High Volume Test</p> <p>Press 5 to test the High volume sounder. This should produce a high volume alarm sound. Press 0 to stop this test.</p>	 <p>The diagrams show the status of indicators during tests 3, 4, and 5. For the Strobe test, the Strobe On indicator is lit. For the Siren test, the External siren indicator is lit. For the Low Volume test, the Internal low volume sound indicator is lit. For the High Volume test, the Internal high volume sound indicator is lit. In all cases, the Day indicator is shown as lit.</p>

Walktest

Press **6** to carry out a walktest. Walk around your property, and in turn cause each of the detectors to go into alarm. Also, open and close all door and windows that are protected by the system. For each detector (including door or window sensor) that is activated the system will produce a series of beeps, and the associated zone indicator will light.

Press **0** to stop this test.

IMPORTANT: Do not test any “Personal Attack” buttons during the walktest, since these are still active and will cause a full alarm.

If any of the alarm tests fail, or you are unsure of the correct procedure, contact your installer.

4.

Press **Reset** to exit Alarm test and press **Reset** again to exit program mode. The **Tamper** indicator will go out and the **Day** indicator will light.

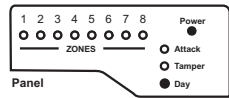
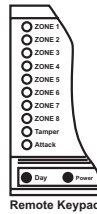

Operating instructions

External siren Time: _____

Siren delay _____

Area protected	Zone name	Program 1	Program 2	Program 3
Zone 1				
Zone 2				
Zone 3				
Zone 4				
Zone 5				
Zone 6				
Zone 7				
Zone 8				

T = Timed (Entry/Exit - Zone)

TI = Time Inhibited (Access zone to keypad)

I = Immediate (All zones armed to give full alarm)



The panels conform to the requirements of the European EMC and Low Voltage directives, and carries the CE mark